

Nikon

En

The ***Nikon*** Guide to Digital Photography
with the

COOLPIX5400

DIGITAL CAMERA

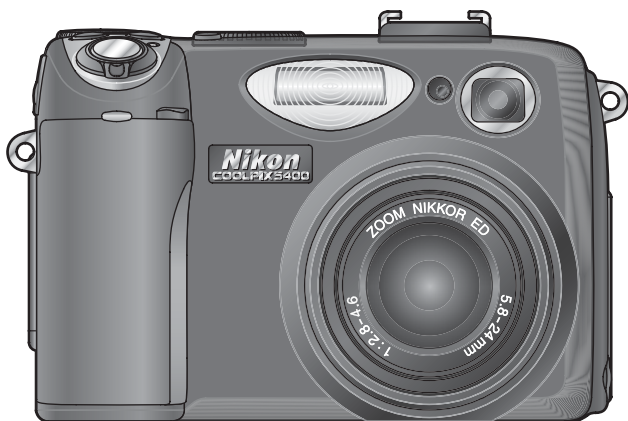

CE

Trademark Information

Apple, the Apple logo, Macintosh, Mac OS, Power Macintosh, PowerBook, and Quick Time are registered trademarks of Apple Computer, Inc. Finder, Power Mac, iMac, and iBook are trademarks of Apple Computer, Inc. Microsoft and Windows are registered trademarks of Microsoft Corporation. Internet is a trademark of Digital Equipment Corporation. CompactFlash is a trademark of SanDisk Corporation. Lexar Media is a trademark of Lexar Media Corporation. Adobe and Acrobat are registered trademarks of Adobe Systems Inc. All other trade names mentioned in this manual or the other documentation provided with your Nikon product are trademarks or registered trademarks of their respective holders.

How to Read This Manual

First, be aware of the warnings, cautions, and notices on pages ii–vi.

Before You Begin

Next, read “Before You Begin” to familiarize yourself with the conventions used in this manual and the names of camera parts.



First Steps

Know where everything is? Then set up your camera as described in “First Steps.”



Basic Photography

Now you are ready to take pictures and view them in the monitor. You can then try your hand at creative composition as described in “Taking Pictures in Scene Mode,” or learn more about flash and focus mode settings.



More on Photography

Once you have mastered the basics of digital photography, read “More on Photography” for information on fine-tuning camera settings for more challenging shots.



More on Playback

See “More on Playback” for information on viewing pictures on the camera, on TV, on a computer, and printing pictures.



Movies

Read “Movies” to learn more about shooting and viewing movies.



Menu Guide

Refer to the “Menu Guide” for information on camera menus.



Technical Notes

“Technical Notes” covers optional accessories, camera care, troubleshooting, and camera specifications.



For Your Safety







To prevent damage to your Nikon product or injury to yourself or to others, read the following safety precautions in their entirety before using this equipment. Keep these safety instructions where all those who use the product will read them.

The consequences that could result from failure to observe the precautions listed in this section are indicated by the following symbol:



This icon marks warnings, information that should be read before using this Nikon product to prevent possible injury.

WARNINGS

-  **Do not look at the sun through the viewfinder**
Viewing the sun or other strong light source through the viewfinder could cause permanent visual impairment.
-  **Turn off immediately in the event of malfunction**
Should you notice smoke or an unusual smell coming from the equipment or from the AC adapter (available separately), unplug the AC adapter and remove the battery immediately, taking care to avoid burns. Continued operation could result in injury. After removing the battery, take the equipment to a Nikon-authorized service representative for inspection.
-  **Do not use in the presence of flammable gas**
Do not use electronic equipment in the presence of flammable gas, as this could result in explosion or fire.
-  **Observe caution when using the camera strap**
Never place the strap around the neck of an infant or child.
-  **Do not disassemble**
Touching the product's internal parts could result in injury. In the event of malfunction, the product should be repaired only by a qualified technician. Should the product break open as the result of a fall or other accident, take the product to a Nikon-authorized service representative for inspection after unplugging the AC adapter and removing the battery.
-  **Observe proper precautions when handling batteries**
Batteries may leak or explode if improperly handled. Observe the following precautions when handling batteries for use in this product:
 - Before replacing the battery, turn the product off and make sure the power-on lamp has gone out. If you are using an AC adapter, be sure it is unplugged.
 - Use only rechargeable Nikon EN-EL1 lithium-ion batteries (supplied) or six-volt 2CR5 (DL245) lithium batteries (available separately).
 - When inserting the battery, do not attempt to insert it upside down or backwards.
 - Do not short or disassemble batteries.
 - Do not expose batteries to flame or to excessive heat.

- Do not immerse in or expose to water.
- Do not transport or store with metal objects such as necklaces or hairpins.
- Batteries are prone to leakage when fully discharged. To avoid damage to the product, be sure to remove the battery when no charge remains.
- Immediately after use, or when the product is used on battery power for an extended period, the battery may become hot. Before removing the battery, turn the camera off and allow the battery to cool.
- The camera grip may become noticeably warm when the camera is used with a 2CR5 (DL245) lithium battery. This is normal and does not indicate a malfunction.
- Discontinue use immediately should you notice any change in the battery, such as discoloration or deformation.

 **Use appropriate cables**

When connecting cables to the input and output jacks, use only the cables provided or sold by Nikon for the purpose, to maintain compliance with product regulations.

 **Keep out of reach of children**

Particular care should be taken to prevent infants from putting the batteries or other small parts into their mouths.

 **Removing memory cards**

Memory cards may become hot during use. Observe due caution when removing memory cards from the camera.

 **CD-ROMs**

The CD-ROMs on which the software and manuals are distributed should not be played back on audio CD equipment. Playing CD-ROMs on an audio CD player could cause hearing loss or damage the equipment.

 **Observe caution when operating the flash**

Using the flash close to your subject's eyes could cause temporary visual impairment. Particular care should be observed if photographing infants, when the flash should be no less than one meter (39") from the subject.

 **When using the viewfinder**

When operating the diopter adjustment control with your eye to the viewfinder, care should be taken to not put your finger in your eye accidentally.

 **Avoid contact with liquid crystal**

Should the monitor break, care should be taken to avoid injury due to broken glass and to prevent liquid crystal from the monitor touching the skin or entering the eyes or mouth.

Cautions

To ensure continued enjoyment of your Nikon product, observe the following precautions when storing or using the device:

- ✔ **Keep dry**
The device will be damaged if immersed in water or subjected to high levels of moisture.
- ✔ **Handle the lens and all moving parts with care**
Do not apply force to the lens, monitor, or to the connector, card slot, or battery chamber covers. These parts are especially susceptible to damage.
- ✔ **Turn the product off before removing or disconnecting the power source**
Do not unplug the product or remove the batteries while the product is on, or while images are being recorded or deleted. Forcibly cutting power in these circumstances could result in loss of data or in damage to product memory or internal circuitry. To prevent an accidental interruption of power, avoid carrying the product from one place to another while the AC adapter (available separately) is connected.
- ✔ **Do not drop**
The product may malfunction if subjected to strong shocks or vibration.
- ✔ **Keep away from strong magnetic fields**
Do not use or store this device in the vicinity of equipment that generates strong electromagnetic radiation or magnetic fields. Strong static charges or the magnetic fields produced by equipment such as radio transmitters could interfere with the monitor, damage data stored on the memory card, or affect the product's internal circuitry.
- ✔ **Avoid sudden changes in temperature**
Sudden changes in temperature, such as occur when entering or leaving a heated building on a cold day, can cause condensation inside the device. To prevent condensation, place the device in a carrying case or a plastic bag before exposing it to sudden changes in temperature.

Notices

- No part of the manuals included with this product may be reproduced, transmitted, transcribed, stored in a retrieval system, or translated into any language in any form, by any means, without Nikon's prior written permission.
- Nikon reserves the right to change the specifications of the hardware and software described in these manuals at any time and without prior notice.
- Nikon will not be held liable for any damages resulting from the use of this product.
- While every effort has been made to ensure that the information in these manuals is accurate and complete, we would appreciate it were you to bring any errors or omissions to the attention of the Nikon representative in your area (address provided separately).

Notice for customers in the U.S.A.

Federal Communications Commission (FCC) Radio Frequency Interference Statement

This equipment has been tested and found to comply with the limits for a Class B digital device, pursuant to Part 15 of the FCC rules. These limits are designed to provide reasonable protection against harmful interference in a residential installation. This equipment generates, uses, and can radiate radio frequency energy and, if not installed and used in accordance with the instructions, may cause harmful interference to radio communications. However, there is no guarantee that interference will not occur in a particular installation. If this equipment does cause harmful interference to radio or television reception, which can be determined by turning the equipment off and on, the user is encouraged to try to correct the interference by one or more of the following measures:

- Reorient or relocate the receiving antenna.
- Increase the separation between the equipment and receiver.
- Connect the equipment into an outlet on a circuit different from that to which the receiver is connected.
- Consult the dealer or an experienced radio/television technician for help.

Nikon	E5400
FC	Tested To Comply With FCC Standards
FOR HOME OR OFFICE USE	

CAUTIONS

Modifications

The FCC requires the user to be notified that any changes or modifications made to this device that are not expressly approved by Nikon Corporation may void the user's authority to operate the equipment.

Interface Cables

Use the interface cables sold or provided by Nikon for your equipment. Using other interface cables may exceed the limits of Class B Part 15 of the FCC rules.

Nikon Inc.,
1300 Walt Whitman Road, Melville, New York
11747-3064, U.S.A.
Tel.: 631-547-4200

Notice for customers in Canada

CAUTION

This class B digital apparatus meets all requirements of the Canadian Interference Causing Equipment Regulations.

ATTENTION

Cet appareil numérique de la classe B respecte toutes les exigences du Règlement sur le matériel brouilleur du Canada.

Notice Concerning Prohibition of Copying or Reproduction

Note that simply being in possession of material that has been digitally copied or reproduced by means of a scanner, digital camera or other device may be punishable by law.

• Items prohibited by law from being copied or reproduced

Do not copy or reproduce paper money, coins, securities, government bonds, or local government bonds, even if such copies or reproductions are stamped "Sample."

The copying or reproduction of paper money, coins, or securities which are circulated in a foreign country is prohibited.

Unless the prior permission of the government has been obtained, the copying or reproduction of unused postage stamps or post cards issued by the government is prohibited.

The copying or reproduction of stamps issued by the government and of certified documents stipulated by law is prohibited.

• Cautions on certain copies and reproductions

The government has issued cautions on copies or reproductions of securities issued by private companies (shares, bills, checks, gift certificates, etc.), commuter passes, or coupon tickets, except when a minimum of necessary copies are to be provided for business use by a company. Also, do not copy or reproduce passports issued by the government, licenses issued by public agencies and private groups, ID cards, and tickets, such as passes and meal coupons.

• Comply with copyright notices

The copying or reproduction of copyrighted creative works such as books, music, paintings, woodcut prints, maps, drawings, movies, and photographs is governed by national and international copyright laws. Do not use this product for the purpose of making illegal copies or to infringe copyright laws.

Table of Contents





How to Read This Manual	i
For Your Safety	ii
Cautions	iv
Notices	v
Before You Begin	1
Introduction	2
Parts of the Camera	4
The Monitor	6
The Mode Dial	8
The Shutter-Release Button	9
The  (Monitor) Button	9
Using the Menus.....	10
Viewing the Menu	10
Making a Selection.....	11
First Steps	13
Inserting Batteries	14
Inserting Memory Cards.....	16
Checking the Battery Level.....	18
Basic Setup	20
Basic Photography	23
Taking Pictures in  Mode	24
Step 1—Select  Mode	24
Step 2—Frame the Picture	26
Step 3—Focus and Shoot	28
Step 4—View the Results.....	31
Flash Photography	32
Focusing Near and Far.....	34
Self-Timer Mode	35
Exposure Compensation.....	36
Taking Pictures in Scene Mode	37
Taking Pictures for a Panorama.....	44
More on Photography	47
Controlling Exposure.....	48
P : Programmed Auto.....	49
S : Shutter-Priority Auto	50
A : Aperture-Priority Auto	51
M : Manual.....	52
Image Quality and Size.....	54
Image Quality.....	54
Image Size	55
Sensitivity (P, S, A, and M)	58

Table of Contents

White Balance (P, S, A and M)	60
Continuous (P, S, A, and M)	63
Sharpening, Contrast, and Color (P, S, A, and M)	65
Image Sharpening	65
Image Adjustment.....	66
Saturation Control.....	67
Metering (P, S, A, and M)	68
More on Focus (P, S, A, and M).....	69
Focus Options	69
Manual Focus.....	72
More on Playback	73
Viewing Pictures on the Camera.....	74
Quick Review and Playback	74
Photo Information	76
Viewing Multiple Pictures: Thumbnail Playback.....	78
Taking a Closer Look: Playback Zoom	79
Adding Audio Commentary: Voice Memo	80
Creating Small Copies: Small Picture.....	81
Viewing Pictures on TV.....	82
Viewing Pictures on a Computer	83
Printing Pictures	86
Movies	87
 Recording Movies	88
Recording a Time-Lapse Movie	90
Viewing Movies	92
Menu Guide.....	93
The Shooting Menu	94
White Balance	96
Metering.....	96
Continuous.....	96
Best Shot Selector (BSS).....	97
Image Adjustment.....	98
Saturation Control.....	98
User Setting	98
Image Quality and Size	100
Sensitivity	100
Image Sharpening	100
Lens	101
Exposure Options	103
Focus Options	105
Zoom Options	105

Controlling the Flash: Speedlight Options	106
Auto Bracketing	109
Noise Reduction	111
Reset	112
My Menu	113
CF Card Format	114
The Playback Menu	115
Delete	116
Folders	118
Slide Show	123
Protect	125
Hide Image	126
Print Set	127
Auto Transfer	129
Move Image	131
CF Card Format	133
Small Pic	133
The Setup Menu	134
Language	135
Date	135
Folders	135
Monitor Options	136
Seq. Numbers	138
Shutter Sound	139
Auto Off	140
CF Card Format	140
Controls	141
Shot Confirmation	143
info.txt	143
USB	144
Video Mode	144
Reset All	144
Date Imprint	145
Firmware Version	145
Technical Notes	147
Optional Accessories	148
Caring for Your Camera	149
Error Messages	151
Troubleshooting	153
Specifications	156
Index	158

Before You Begin

Read this chapter to familiarize yourself with the symbols and conventions used in this manual, camera controls and displays, and menu operations.

Introduction.....		2
Parts of the Camera		4
Using the Menus		10

Introduction



Thank you for your purchase of a Nikon COOLPIX5400 digital camera. This manual has been written to help you enjoy taking pictures with your Nikon digital camera. Read this manual thoroughly before use, and keep it where all those who use the product will read it.

To make it easier to find the information you need, the following symbols and conventions are used:



This icon marks cautions, information that should be read before use to prevent damage to the camera.



This icon marks tips, additional information that may be helpful when using the camera.



This icon marks notes, information that should be read before using the camera.



This icon indicates that more information is available elsewhere in this manual or in the *Quick Start Guide*.

Use Only Nikon Brand Electronic Accessories

Nikon COOLPIX cameras are designed to the highest standards and include complex electronic circuitry. Only Nikon brand electronic accessories (including battery chargers, batteries, and AC adapters) certified by Nikon specifically for use with this Nikon digital camera are engineered and proven to operate within the operational and safety requirements of this electronic circuitry.

THE USE OF NON-NIKON ELECTRONIC ACCESSORIES COULD DAMAGE THE CAMERA AND MAY VOID YOUR NIKON WARRANTY.

For more information about Nikon brand accessories, contact a local authorized Nikon dealer.

Before Taking Important Pictures

Before taking pictures on important occasions (such as at weddings or before taking the camera on a trip), take a test shot to ensure that the camera is functioning normally. Nikon will not be held liable for damages or lost profits that may result from product malfunction.

Life-Long Learning

As part of Nikon's "Life-Long Learning" commitment to ongoing product support and education, continually-updated information is available on-line at the following sites:

- For users in the U.S.A.: <http://www.nikonusa.com/>
 - For users in Europe: <http://www.nikon-euro.com/>
 - For users in Asia, Oceania, the Middle East, and Africa: <http://www.nikon-asia.com/>
- Visit these sites to keep up-to-date with the latest product information, tips, answers to frequently-asked questions (FAQs), and general advice on digital imaging and photography. Additional information may be available from the Nikon representative in your area. See the URL below for contact information:

<http://www.nikon-image.com/eng/>

Design Rule for Camera File System (DCF)

This camera conforms to the Design Rule for Camera File System (DCF), a standard widely used in the digital camera industry to ensure compatibility among different makes of camera.

Exif Version 2.2

This camera supports Exif (Exchangeable Image File Format for Digital Still Cameras) version 2.2 (Exif Print), a standard that allows information stored with pictures to be used for optimal color reproduction when images are output on Exif-compliant printers.

Parts of the Camera



Before You Begin

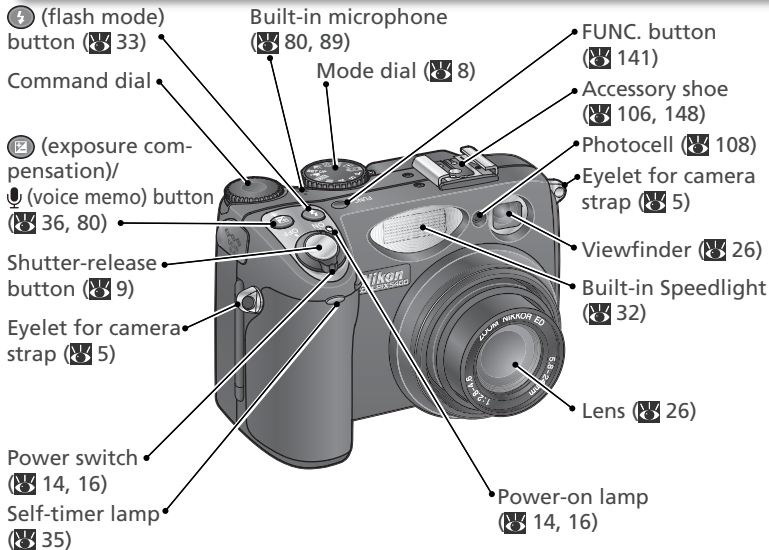

Battery-chamber cover (14)

USB (digital I/O) connector (under cover; 84)

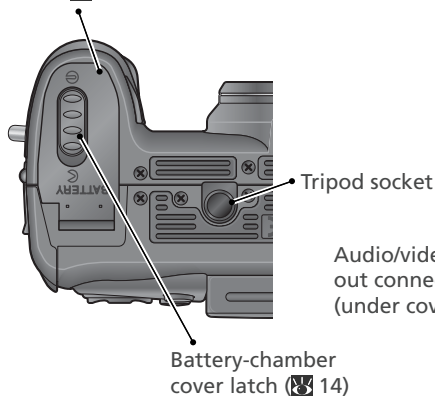

Audio/video (AV) out connector (under cover; 82)

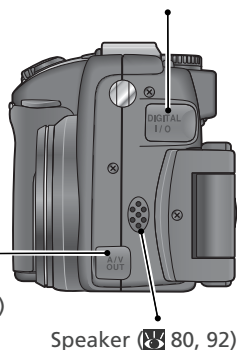

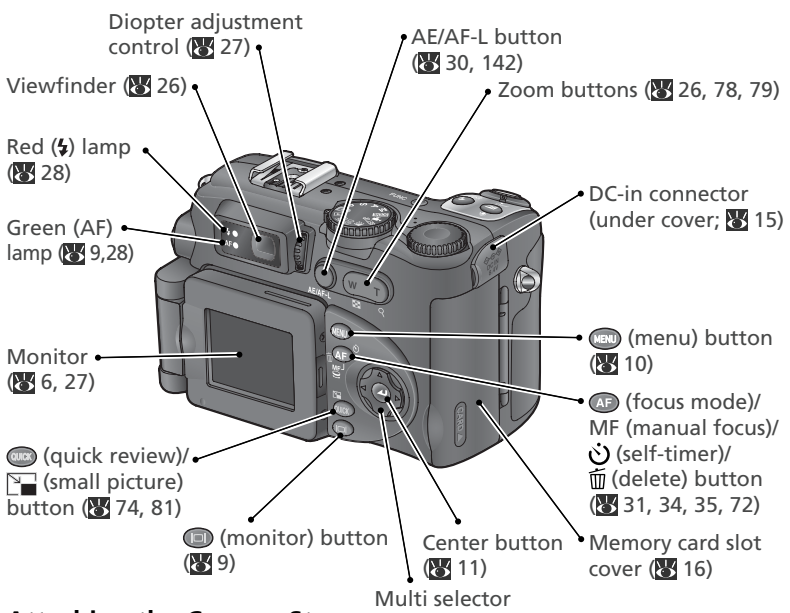

Attaching the Camera Strap

Attach the camera strap as shown below. Repeat for the second eyelet.

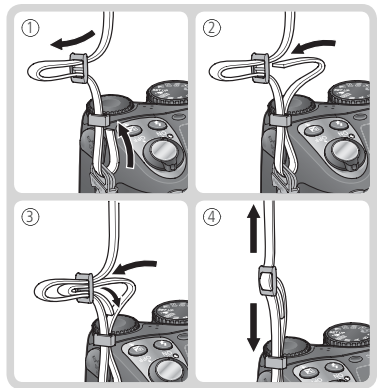

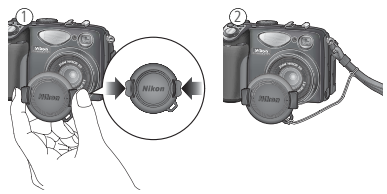

The Lens Cap

When replacing or removing the lens cap, press the tabs on either side of the cap to release the latch (1). To avoid losing the lens cap, use the cord provided to attach it to the camera as shown (2).



The Monitor

During shooting, the monitor shows the view through the camera lens, together with icons indicating the status of various camera settings (see opposite). The monitor is also used to display pictures during quick review ( 74) and playback ( 75).



Fold out to use

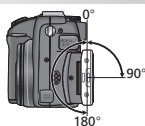

Range of rotation



Frame self-portraits*



Stow on camera body



Storage position
(monitor turns off)

* When swivelled to point in same direction as the lens, the monitor shows a mirror image of what will appear in the final picture.

Using the Monitor

Do not apply excessive force to the monitor when it is folded out from the camera body. Failure to observe this precaution could damage the hinge that connects the monitor to the camera.

When the Monitor Is in the Storage Position

The only controls that can be used when the monitor is off are the shutter-release and zoom buttons (optical zoom only). To use digital zoom ( 26) and other camera controls, fold the monitor out.

The following indicators appear in the monitor during shooting:

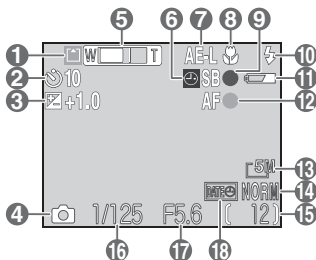

and **SCENE** modes

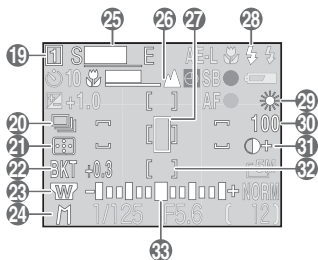

P, S, A, and M modes

1	Recording indicator	29
2	Self-timer indicator	35
3	Exposure compensation	36
4	Shooting mode	25, 38
5	Zoom indicator	26
	Folder name	135
6	"Date not set" icon*	21
7	Exposure lock	30
8	Focus mode	34
9	Flash-ready indicator	28
10	Flash mode	33
11	Battery level indicator	18
12	Focus indicator	28
13	Image size	56
14	Image quality	56
15	Number of exposures remaining/ length of movie	25, 88
16	Shutter speed	50
17	Aperture	51
18	Date imprint indicator	145

19	User Setting bank	98
20	Continuous shooting mode	63
	Noise reduction	111
21	Metering mode	68
22	Bracketing indicator	109
	Best Shot Selector (BSS)	97
23	Lens converter setting	101
24	Exposure mode	48
25	Ultra HS recording indicator	64
26	Manual focus display	72
27	Spot metering exposure target	68
28	Flash mode for optional Speedlights	108
29	White balance	60
30	Sensitivity (ISO equivalency)	58
31	Image adjustment/black-and- white indicator	66, 67
32	Focus areas	70
33	Exposure display	53

* Appears when camera clock has not been set.

The Mode Dial

To select a mode, align the mode icon with the "□" mark next to the mode dial.



Exposure Mode (📷 48)

P, **S**, **A**, and **M** modes offer varying degrees of control over shutter speed and aperture. A shooting menu is available which grants access to advanced settings such as metering and image sharpening.

📷 Auto (📷 24)

A simple "point-and-shoot" mode in which the majority of camera settings are controlled by the camera. Recommended for first-time users of digital cameras.

▶ Playback (📷 75)

Play pictures back in the monitor.

WB (📷 60)

Display a menu of white balance options.

SCENE Scene (📷 38)

Choose from fifteen "scenes" suited to different subjects or shooting conditions and let the camera do the rest.

🎬 Movie (📷 88)

Choose from three movie modes.

SET UP (📷 134)

Choose this mode to display the setup menu, where you can perform such tasks as setting the camera clock and adjusting monitor brightness.

🔍 (📷 56)

Display a menu of image quality and size options.

ISO (📷 59)

Display a menu of sensitivity (ISO equivalency) options.



The Shutter-Release Button

The camera has a two stage shutter-release button. The camera sets focus and exposure when the button is pressed halfway. The green (AF) lamp next to the viewfinder will light when the focus operation is complete. Focus and exposure will remain locked while the shutter-release button is pressed halfway. To take the picture, press the shutter-release button the rest of the way down.

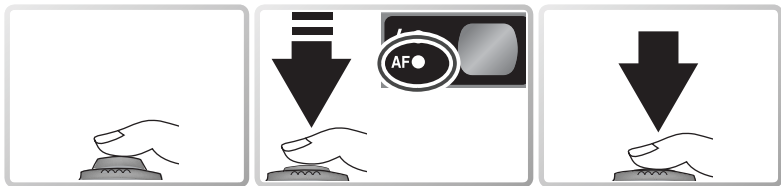

The (Monitor) Button

The  button controls the monitor.



Monitor shows current settings and view through lens

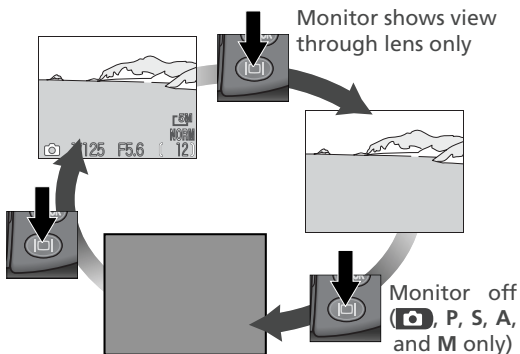

The monitor turns off automatically when face down on the camera body.

Using the Menus

Viewing the Menus

To view the menu for **P**, **S**, **A**, **M**, **SCENE**, , or  mode, rotate the mode dial to the desired setting and press the  button. The menu for the current mode will be displayed in the monitor.

1

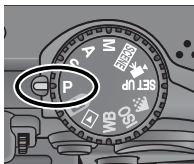

Select mode.

2



Menu for current mode displayed.

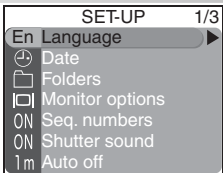
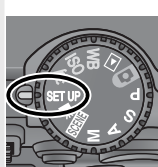

When the mode dial is rotated to **SET UP**, , **ISO**, or **WB**, the menu for the selected mode will automatically be displayed in the monitor.



Menu for selected mode displayed.

No menu is available in  mode.

Exiting the Menus

To exit the menus and return to shooting or playback, press the  button. To exit the menu displayed when the mode dial is set to **SET UP**, , **ISO**, or **WB**, rotate the mode dial to another setting.

Taking Pictures while Menus Are Displayed

In **P**, **S**, **A**, **M**, **SCENE**, and  modes, the monitor will show the view through the camera lens when the shutter-release button halfway. To take a picture, press the shutter-release button all the way down. The menu will be displayed again when shooting ends.

Making a Selection

Use the multi selector to make a selection from the menus.

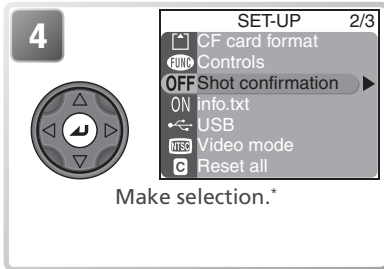
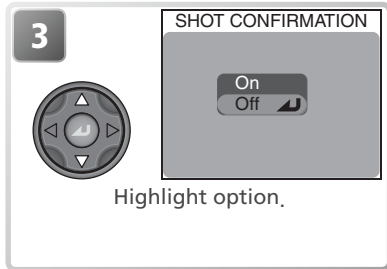
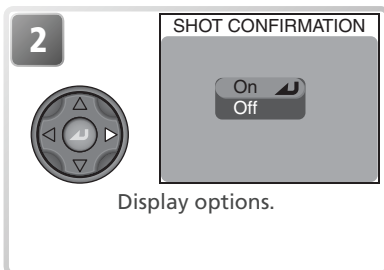
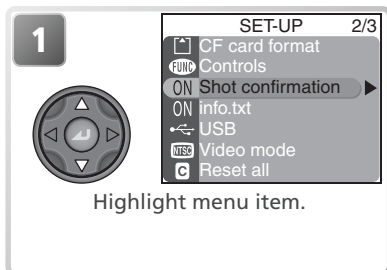

* Selection can also be made by pressing multi selector to right.

- The selection for some options is made from a sub-menu. Repeat steps 2 and 3 to make a selection from a sub-menu.
- To go back one step, press the multi selector to the left.
- If the menu has more than one page of options, press the multi selector up or down to scroll to the next page.

First Steps

This chapter details the steps you will take before using the camera for the first time.

Inserting Batteries 14

For more on batteries and alternative power sources, see:

- Technical Notes: Optional Accessories (148)

Inserting Memory Cards 16

For more on formatting memory cards, see:

- The Shooting Menu: CF Card Format (114)

Checking the Battery Level 18

Basic Setup 20

To learn more about camera setup options, see:

- The Setup Menu (134)

Inserting Batteries

A Nikon EN-EL1 rechargeable lithium-ion battery is included with the camera. Charge the battery as necessary using the battery charger provided (about two hours are required to charge an EN-EL1 battery when no charge remains). For more information, see the documentation provided with the battery charger. Note that EN-EL1 batteries must be charged before first use.

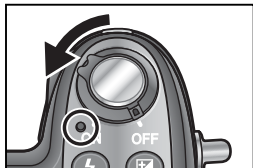

- 1 Turn the camera off**
Check that the power-on lamp is off.

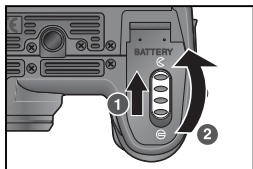

- 2 Open the battery-chamber cover**
Slide the battery-chamber latch to the open position (Ⓐ; ①) and flip the battery-chamber cover open (②).

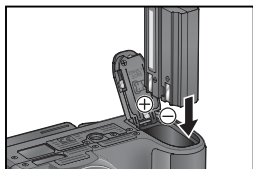

- 3 Insert the battery**
Insert the battery as shown in the label inside the battery chamber.

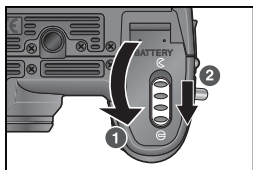

- 4 Close the battery-chamber cover**
Close the battery-chamber cover (Ⓐ) and slide the latch to the closed position (Ⓑ; ②). Be sure that the battery-chamber cover is properly latched.

✓ Read Battery Warnings

Read and follow the battery warnings and cautions on pages ii–iv and 150 of this manual, together with any warnings and instructions supplied by the battery manufacturer.

✓ Replacing Batteries

Before removing or inserting batteries, make sure that the camera is off. **Do not open the battery chamber cover while the power-on lamp is lit.** To remove the battery, open the battery chamber cover as described in Step 2 on the preceding page and slide the battery out.

✓ Alternative Power Sources

- To power the camera continuously for extended periods, use an EH-53 AC adapter or an EH-21 AC adapter/battery charger (Ⓜ 148), which doubles as a battery charger for EN-EL1 batteries. **Do not, under any circumstances, use another make or model of AC adapter.** Failure to observe this precaution could result in overheating or in damage to the camera.
- The camera can also be powered by a six-volt 2CR5 (DL245) lithium battery. We recommend buying 2CR5 (DL245) batteries as a back-up power source. Insert 2CR5 batteries as shown at right.

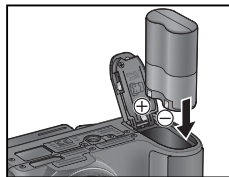

Inserting Memory Cards

The camera stores pictures on CompactFlash™ memory cards.

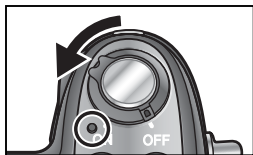

- 1 Turn the camera off
Check that the power-on lamp is off.

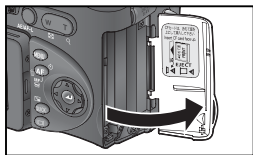

- 2 Open the memory card slot cover

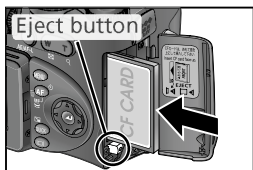

- 3 Insert the memory card
Check that the eject button is all the way down, then insert the memory card in the direction of the arrow as shown in the label on the underside of the memory card slot cover.

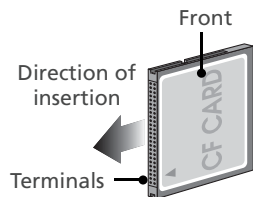

✓ Inserting Memory Cards

Insert the memory card terminals first. Inserting the card upside down or backwards could damage the camera or the card. Check to be sure that the card is in the correct orientation.

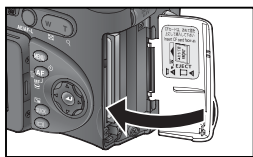

- 4 Close the memory card slot cover

✓ Closing the Card-Slot Cover

If the eject button is up when the card-slot cover is closed, closing the cover will partially eject the memory card, causing errors when the camera is turned on. Be sure the eject button is down before inserting memory cards.

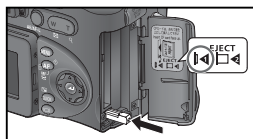

✍ Formatting Memory Cards

The memory card supplied with the camera is formatted at shipment. Other memory cards must be formatted before first use. For information on formatting memory cards, see "Shooting Menu Options: CF Card Format" (📷 114).

🔍 Removing Memory Cards

Memory cards can be removed without loss of data when the camera is off. To remove memory cards, turn the camera off and open the card slot cover. Press the eject button to pop it up (①), then press it again to partially eject the card (②). The card can then be removed by hand. Note that memory cards may become hot during use; observe due caution when removing memory cards.

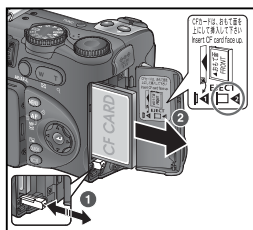

🔍 Approved Memory Cards

In addition to the card provided with your camera, the following memory cards have been tested and approved for use with your Nikon digital camera:

Nikon	EC-CF	All capacities
SanDisk	SDCFB	32 MB, 64 MB, 128 MB, 256 MB, 512 MB, 1 GB
	SDCFH Ultra	128 MB, 192 MB, 256 MB, 384 MB, 512 MB
Lexar Media	4x USB	16 MB, 32 MB, 64 MB, 128 MB, 256 MB, 512 MB
	8x USB	
	12x USB	64 MB, 128 MB, 256 MB, 512 MB
	16x USB	
	24x USB/WA (Write Acceleration) USB	
Hitachi (Renesas Technology)	Compact FLASH HB28	128 MB, 256 MB, 512 MB
Microdrive	DSCM	10512 (512MB), 11000 (1 GB)

Operation is not guaranteed with other makes of memory card. For more details on the above cards, please contact the manufacturer.

Checking the Battery Level

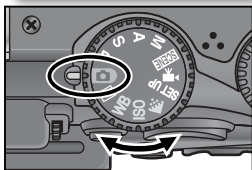

1 Select  mode

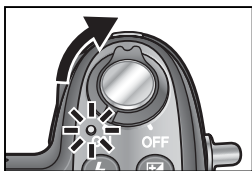

2 Turn the camera on
The power-on lamp will light.





3 Check the battery level in the monitor
For information on opening the monitor, see "Parts of the Camera: The Monitor" (6).



Display	Meaning
NO ICON	Charge sufficient for normal operation.
	Low battery; fewer shots can be taken consecutively in "continuous" mode. Ready spare battery.
WARNING !! BATTERY EXHAUSTED	Battery exhausted. Replace with fully-charged battery.

The power-on lamp will blink when the "battery exhausted" warning is displayed.

Auto Power Off (Standby Mode)

If no operations are performed for one minute (three minutes when menus are displayed), the monitor will turn off automatically and the camera will enter standby mode to reduce the drain on the batteries (when the camera is powered by an AC adapter, the monitor will turn off after thirty minutes). The camera can be reactivated by:

- Pressing the shutter-release button halfway
- Pressing the  button
- Pressing the  button to display the menu for the current mode
- Pressing the  button to enter quick review
- Rotating the mode dial to select a new mode

The length of time before the camera enters standby mode can be changed using the **Auto off** option in the setup menu ( 140). The camera will not enter standby mode when connected to a computer ( 83).

Basic Setup

Before using the camera for the first time, choose a language for camera menus and messages and set the camera clock to the correct time and date.

1



SET-UP 1/3

- En Language
- Date
- Folders
- Monitor options
- 0N Seq. numbers
- 0N Shutter sound
- 1m Auto off

Rotate mode dial to **SET UP** and turn camera on.

2



SET-UP 1/3

- En Language
- Date
- Folders
- Monitor options
- 0N Seq. numbers
- 0N Shutter sound
- 1m Auto off

Highlight **Language**.

3



LANGUAGE

- De Deutsch
- En English
- Fr Français
- 日本語
- Es Español

Display options.

4



LANGUAGE

- De Deutsch
- En English
- Fr Français
- 日本語
- Es Español

Choose language from **Deutsch** (German), **English**, **Français** (French), **日本語** (Japanese), or **Español** (Spanish).

5



SET-UP 1/3

- En Language
- Date
- Folders
- Monitor options
- 0N Seq. numbers
- 0N Shutter sound
- 1m Auto off

Return to setup menu.

6



SET-UP 1/3

- En Language
- Date
- Folders
- Monitor options
- 0N Seq. numbers
- 0N Shutter sound
- 1m Auto off

Highlight **Date**.

The Clock Battery

When the main batteries are installed or the camera is powered by an AC adapter, the clock battery will charge in about ten hours. When fully charged, the clock battery can provide several days of back-up power.

7

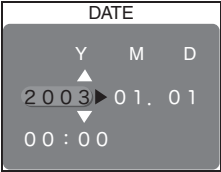
Display DATE menu.

8

Edit Year.

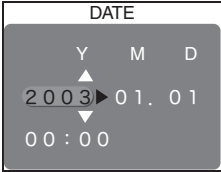
9

Select Month. Repeat steps 8-9 to edit remaining items.

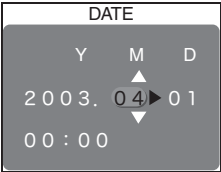
10

Highlight Y M D.

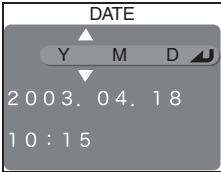
11

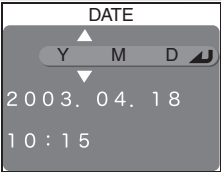

Choose order in which Year, Month, and Day will be displayed.

12

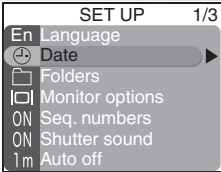















Return to setup menu.

The Icon

If the  ("date not set") icon  7) flashes in the monitor when the camera is in shooting mode, the date and time have not been set or the clock battery is exhausted. Set the camera clock as described above. Still pictures taken before the clock has been set will have a time stamp of "0000.00.00 00:00," movies a time stamp of "2003.01.01 00:00."

Basic Photography

This chapter covers the basics of taking pictures and playing them back. It also describes how to take pictures in scene mode.

Taking Pictures in  Mode	 24
Step 1 Select  Mode 	24
<i>For more about the mode dial, see:</i>	
• Before You Begin: The Mode Dial  8	
Step 2 Frame the Picture 	26
Step 3 Focus and Shoot 	28
<i>For more about focus options, see:</i>	
• Basic Photography: Focusing Near and Far  34	
• More on Photography: More on Focus  69	
<i>For information on using the self-timer, see:</i>	
• Basic Photography: Focusing Near and Far  34	
Step 4 View the Results 	31
<i>For more about playback, see:</i>	
• More on Playback  73	
Flash Photography	 32
Focusing Near and Far	 34
Exposure Compensation.....	 36
Taking Pictures in Scene Mode.....	 37

Taking Pictures in Mode

This section details the basic steps involved in taking pictures in  (auto) mode. In this automatic, “point-and-shoot” mode, the majority of camera settings are controlled by the camera in response to shooting conditions, producing optimal results in most situations.

Step 1—Select Mode

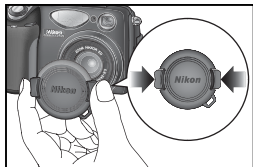

1 Remove the lens cap

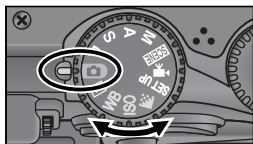

2 Rotate the mode dial to 

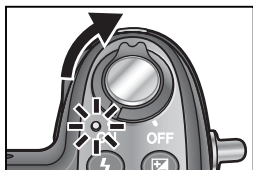



3 Turn the camera on
A beep will sound and the power-on lamp will light. The camera is ready to shoot when the monitor shows the view through the camera lens.

Autofocus (Mode)

When the monitor is on in  mode, the camera focuses continuously until the shutter-release button is pressed halfway. When the monitor is off, the camera focuses when the shutter-release button is pressed halfway.

P, S, A, and M Modes

In addition to the options available in  mode, **P**, **S**, **A**, and **M** modes offer control over shutter speed and aperture, manual focus, and such shooting menu settings as white balance and sensitivity (ISO equivalency), allowing settings to be adjusted for more challenging shots. See “More on Photography” ( 47) and “The Shooting Menu” ( 94).

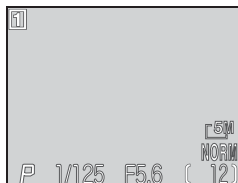

Flash mode

Choose from six options depending on lighting and your creative intent (📷 32). At the default setting (auto), the flash fires automatically when lighting is poor. No icon is displayed in auto mode.

Image size

Choose from six options depending on how picture will be used (📷 55). The default setting is **5M** (2592 × 1944).

Shooting mode

The current shooting mode or scene selection is displayed here.

Image quality

Choose from four options depending on how picture will be used (📷 54). The default setting is **NORMAL**.

Shutter speed

Aperture

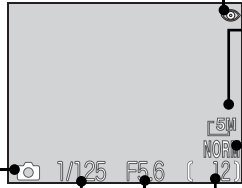

Number of exposures remaining

The number of pictures that can be stored on a memory card depends on the capacity of the card and the current image quality and size.

📷 Number of Exposures Remaining

If the number of exposures remaining is zero, the message "OUT OF MEMORY" will be displayed in the monitor. No further pictures can be taken until:

- a new memory card is inserted (📷 16)
- pictures are deleted (📷 116)

It may also be possible to take additional pictures at a lower image quality or size (📷 54).

📷 Using the Self-Timer

The self-timer can be used to delay shutter release by three or ten seconds. See "Basic Photography: Focusing Near and Far" (📷 34).

Step 2—Frame the Picture

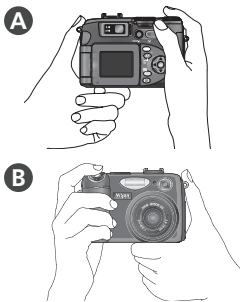

- 1 **Ready the camera**
Hold the camera steadily in both hands. Photographs can be framed in the monitor **A** or the viewfinder **B**.

Don't Block the Shot

To avoid dark or partially obscured pictures, keep fingers and other objects away from the lens and flash window.



Zoom out Zoom in



Indicator in monitor shows amount of zoom when either button is pressed





Digital zoom

- 2 **Frame the subject**
The camera is equipped with two types of built-in zoom: optical zoom, in which the camera's telescoping lens can be used to magnify the subject up to 4x, and digital zoom, in which digital processing is used to further magnify the image up to 4x, for a total of 16x. Use the zoom buttons to frame your subject in the center of the monitor:
 - Press the **W** button to zoom out from the subject, increasing the area visible in the frame.
 - Press the **T** button to zoom in on the subject so that it fills a larger area of the frame.
 - When the camera is zoomed in to maximum magnification, holding the **T** button down for about two seconds will trigger digital zoom. The zoom indicator will turn yellow, and the green (AF) lamp next to the viewfinder will blink. Use the **T** and **W** buttons to adjust zoom in the digital zoom range. To cancel digital zoom, press **W** until the zoom indicator turns white.

Monitor or Viewfinder?

Use the monitor to confirm camera settings at a glance while at the same time viewing an image that shows how the final picture will appear. This is particularly useful when the image in the viewfinder does not accurately reflect what will appear in the final picture, for example when:

- the subject is close to the camera (particularly if the range is 50 cm/1'8" or less)
- digital zoom is in effect ( 26)
- image size is set to **3:2** 2592 × 1728 ( 55)
- an optional converter lens is mounted on the camera ( 148)

Use the viewfinder when the monitor has been turned off to save power ( 9), or when bright ambient lighting makes it difficult to see the display in the monitor.

Framing Pictures in the Viewfinder

- At ranges of 1.5 m/4'11" or less, use the smaller of the two frames in the viewfinder display.
- In  mode, the camera focuses on the subject in the center of the frame, shown by the focus brackets in the viewfinder. When framing pictures in the viewfinder, make sure the focus brackets are over the subject before pressing the shutter-release button halfway.

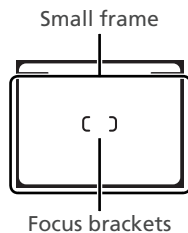

Viewfinder Focus

If the focus brackets in the viewfinder seem blurred, the viewfinder is not in focus. Rotate the diopter adjustment control until the brackets are in sharp focus when your eye is to the viewfinder.



Using the Diopter Control

When operating the diopter control with your eye to the viewfinder, care should be taken to avoid accidentally putting your fingers or fingernails in your eye.

Digital Zoom

In digital zoom, data from the camera's image sensor are processed digitally, enlarging the center portion of the picture to fill the frame. Unlike optical zoom, digital zoom does not increase the amount of detail visible in the picture. Instead, details visible at maximum optical zoom are simply enlarged, producing a slightly "grainy" image. Digital zoom is not available when the monitor is off or in the storage position.

Step 3—Focus and Shoot

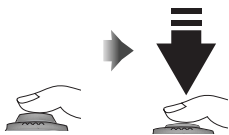

1 Focus
 Press the shutter-release button halfway to set focus and exposure. In mode, the camera will automatically focus on the subject at the center of the frame. Focus and exposure will lock while the shutter-release button is pressed halfway.

With the shutter-release button pressed halfway, check focus and flash. Focus is indicated by the green AF (autofocus) lamp next to the viewfinder and the focus indicator in the monitor. Flash status is shown by the red (flash-ready) lamp next to the viewfinder and the flash-ready indicator in the monitor.

Red lamp

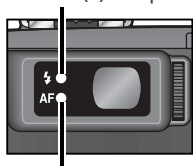

Green (AF) lamp

Flash-ready indicator

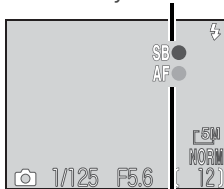

Focus indicator

Red lamp/ flash-ready indicator	On	Flash will fire when picture is taken.
	Blinks (red lamp only)	Flash charging. Briefly lift finger from shutter-release button, then try again.
	Off	Flash off or not required.
Green (AF) lamp/ focus indicator	On	Subject in focus.
	Flickers	Camera unable to focus on subject in focus area. Using focus lock (29), focus on another subject at same distance, then recompose picture and shoot.

If Both the Green and Red Lamps Blink

If the green (AF) and red lamps blink together, an error has occurred. Check the message displayed in the monitor (151).



- 2** Take the picture
 Press the shutter release button the rest of the way down to take the picture. To prevent blur, press the shutter-release button down smoothly.

More on: Autofocus and Focus/Exposure Lock

Autofocus performs best when:

- There is contrast between the subject and the background. Autofocus may not perform well if, for example, the subject is the same color as the background.
- The subject is evenly lit.





Autofocus does not perform well when:

- The focus area contains objects at different distances from the camera. For example, autofocus may not perform well with objects inside a cage, because the bars of the cage will be closer to the camera than the main subject and both the bars and the main subject will be in the focus area.
- The main subject is very dark (the subject should not, however, be too much brighter than the background).
- The subject is moving rapidly.

If the camera is unable to focus using autofocus, the green (AF) lamp will flicker when the shutter-release button is pressed halfway. Use focus lock (see overleaf) to focus on another subject at the same distance, or use manual focus (72).

Continued on page 30

✓ During Recording

While pictures are being recorded to the memory card, the green (AF) lamp will blink and a  (recording) or  (wait) icon will be displayed in the monitor. The camera can continue to take pictures until the  icon is displayed. **Do not turn the camera off, eject the memory card, or remove or disconnect the power source while the green (AF) lamp is blinking or the  or  icon is displayed.** Cutting power or removing the memory card in these circumstances could result in loss of data or in damage to the camera or card.

✍ When the Monitor Is Off

When the monitor is off, pictures can only be taken when the camera is in focus.



More on: Autofocus and Focus/Exposure Lock (continued from page 29)

If the subject is not in the active focus area when the shutter-release button is pressed halfway, the picture may be out of focus. To focus on a subject that will not be in the active focus area in the final composition, use focus lock:

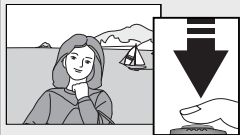

1 Focus

Position the subject in the center of the frame and press the shutter-release button halfway.



2 Check the green (AF) lamp

With the shutter-release button pressed halfway, check that the green (AF) lamp glows steadily, indicating that the subject is in focus. Focus and exposure will remain locked while the shutter-release button is pressed halfway.



3 Recompose the picture

Keeping the shutter-release button pressed halfway, recompose the picture. Do not change the distance between camera and subject while focus lock is in effect. If the subject moves, focus again at the new distance.



4 Take the picture

Smoothly press the shutter-release button all the way down to shoot.

Locking Focus between Shots

To take a series of pictures without stopping to adjust focus, keep the shutter-release button pressed halfway between shots.

The AE/AF-L Button

Focus and exposure can also be locked by pressing the AE/AF-L button. By default, the AE/AF-L button locks both focus and exposure. When **AE-L** is selected for the **Controls > AE-L, AF-L** option in the setup menu (142), the AE/AF-L button will lock only exposure, while pressing the shutter-release button halfway will lock only focus (select **AF-L** to assign focus lock to the AE/AF-L button and exposure lock to the shutter-release button). This can be used with spot, center-weighted, or spot AF area metering (68) to meter one area of a high-contrast subject while focusing on another.

Step 4—View the Results



- 1 Rotate the mode dial to . The most recent picture will be displayed in the monitor.

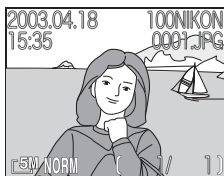

- 2 View additional pictures. To view additional pictures, press the multi selector down or right to view pictures in the order recorded, up or left to view pictures in reverse order. Keep the multi selector pressed to scroll quickly to the desired frame.





To return to shooting mode, rotate the mode dial to .

Viewing Pictures

Pictures are displayed briefly at low resolution while being read from the memory card.



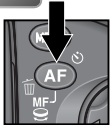



Deleting Unwanted Pictures

To delete the picture currently displayed in the monitor:



<p>1</p>  <p>Confirmation dialog displayed.</p>	<p>SELECTED IMAGES</p> <p>Erase 1 image(s)?</p> <p>No Yes</p>	<p>2</p>  <p>Highlight Yes (to exit without deleting picture, highlight No and press center of multi selector).</p>
<p>3</p> 	<p>Done</p>	<p>Delete picture and return to playback.</p>

Flash Photography

Select a flash mode according to lighting conditions. The following options are available:

Option	How it works	When to use it
NO ICON Auto	Flash fires when lighting is poor.	Best choice in most situations.
 Flash Cancel (off)	Flash will not fire even when lighting is poor.	Use when subject is not in range of flash, to capture natural lighting, or where flash photography is prohibited. If red  lamp flickers, care should be taken to prevent blur.
 Auto with red-eye reduction	Pre-flash fires before main flash, minimizing “red eye” caused by flash reflecting from retina.	Use for portraits (works best when subject is well within range of flash and looking at pre-flash). Not recommended when quick shutter response is required.
 Anytime Flash (fill flash)	Flash fires whenever picture is taken.	Use to “fill-in” (illuminate) shadows and back-lit subjects.
 Slow sync	Auto flash combined with slow shutter speeds.	Use to capture both subject and background at night or under dim light. Care should be taken at slow shutter speeds to prevent blur.
 Rear-curtain sync	As for slow sync, except that flash does not fire until just before shutter closes.	Creates effect of stream of light behind moving objects. Care should be taken at slow shutter speeds to prevent blur.

Speedlight Options/Repeating Flash

The **Speedlight opt.** item in the shooting menu for **P**, **S**, **A**, and **M** modes provides options for controlling the built-in and optional Speedlights ( 148). To capture a moving object multiple times in a single frame, choose mode **M**, set shutter speed to BULB or TIME, and select **On** for **Speedlight opt.** > **Repeating flash** ( 107). Use of a tripod is recommended.

Optional Speedlights

Optional flash accessories can be mounted on the camera's accessory shoe ( 4).

Sensitivity (ISO Equivalency; 58)

A sensitivity setting of 400 is not recommended when using the flash.

To choose a flash mode:

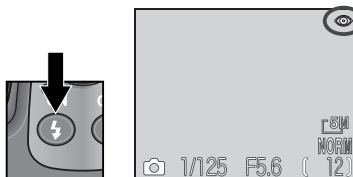

Press  button until desired mode displayed in monitor.

Flash Range

Flash range varies with zoom position. When the camera is zoomed all the way out, the flash has a range of 0.5–4.5 m/1'8"–14'9" (Auto ISO). The range at maximum zoom is 0.5–2.8 m/1'8"–9'2" (Auto ISO). At ranges of 0.5 m (1'8") or less, the flash may be unable to light the entire subject. When using the flash at short range, play pictures back after shooting to check the results.

The Flash-Ready Light

A short pause is required between exposures for the flash system to charge. If the red  lamp next to the viewfinder blinks when the shutter-release button is pressed halfway, the flash is charging. Lift your finger briefly from the shutter-release button and try again.





Low Battery

If the built-in Speedlight fires while the  (low battery) icon is displayed, the monitor will turn off while the flash system charges.

Keep the Flash Window Clear



Keep your fingers and other objects away from the flash window and photocell. If a shot seems dark even though the flash has fired, you may have accidentally blocked the flash window. Check that the flash is unobstructed and try again.

When Lighting Is Poor

When lighting is poor and the flash is off () or set to slow sync () or rear-curtain sync (), shutter speed slows and pictures may be blurred. At speeds below $\frac{1}{4}$ s, the shutter-speed indicator in the monitor will turn yellow to indicate that pictures may be affected by "noise" in the form of randomly-spaced, bright pixels. Noise can be reduced by turning noise reduction on ( 111). At speeds slower than $\frac{1}{30}$ s, we recommend using a tripod or resting the camera on a steady, level surface.

Focusing Near and Far

Choose a focus mode according to your subject and composition.

Option	How it works	When to use it
NO ICON Autofocus	Camera automatically adjusts focus according to distance to subject.	Use when subject is 50 cm (1'8") or more from lens.
 Infinity	Focus is fixed at infinity. Flash is disabled.	Use when shooting distant scenes through foreground objects such as windows.
 Macro close-up	Camera can focus on objects as close as 1 cm (0.4") to lens.	Use for close-ups.
 Self-timer	Combines autofocus (see above) at distances of 1 cm (0.4") or more with shutter-release delay of 10 s or 3 s.	Use for self portraits or to prevent pictures from blurring when shutter-release button is pressed.

To choose a focus mode:

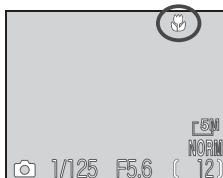
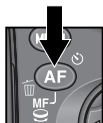

Press  button until desired mode is displayed in monitor.

Macro Close-Up

Minimum focus distance varies with zoom position. To focus as close as 1 cm (0.4") to the lens, zoom the camera out until the  icon in the monitor turns green.

Manual Focus

For information on manual focus, see "More on Photography: Manual Focus" ( 72).

Self-Timer Mode

The self-timer is generally used for self-portraits or when taking low-light or close-up shots without a flash, when it prevents pictures from being blurred by camera movement that occurs when the shutter-release button is pressed.

When using the self-timer option, mount the camera on a tripod (recommended) or rest it on a flat, level surface.

<p>1</p>	<p>2</p>
<p>Press AF (⏻) button until and icons are displayed in monitor. Adjust settings and frame picture.</p>	<p>Check focus.</p>
<p>3</p>	<p>Start timer. Press once for delay of about 10s, twice for delay of about 3s. Press a third time to turn self-timer off. Count-down timer in monitor shows number of seconds remaining until shutter is released.</p>

The Self-Timer

The **Continuous** option in the shooting menu is automatically set to **Single** while the self-timer is on. The self-timer is not available in movie mode or when **Fireworks show** is selected in the scene-mode menu.

Manual Focus

Select the self-timer before choosing a focus distance. Choosing another focus mode will automatically cancel manual focus.

Exposure Compensation

To obtain the desired results with certain compositions (for example, when large areas of the frame are very bright, very dark, or contain areas of high contrast), it may be necessary to alter exposure from the value suggested by the camera. This can be done using exposure compensation.

Exposure compensation can be set to values between -2.0EV (underexposure) and $+2.0\text{EV}$ (overexposure) in increments of $\frac{1}{3}\text{EV}$. To choose a value for exposure compensation, press the  button and rotate the command dial:

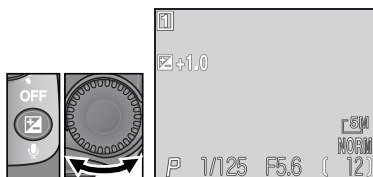

Compensation displayed in monitor at values other than ± 0 . Check image in monitor before shooting.















To cancel exposure compensation, choose a value of ± 0 . In  and **SCENE** modes, exposure compensation will be reset to ± 0 when the camera is turned off or the mode dial is turned to another setting.

Choosing a Value for Exposure Compensation

As a rule of thumb, select *positive* values when large areas of the frame are very brightly lit (for example, when photographing an expanse of sunlit water, sand, or snow) or when the background is much brighter than the main subject. Choose *negative* values when large areas of the frame are very dark (for example, when photographing a forest of dark green leaves) or when the background is much darker than the main subject. This is because the camera, in order to avoid extreme under- or over-exposure, tends to lower exposure when the frame is very bright and raise exposure when the frame is very dark, which can make naturally bright subjects look dim and naturally dark subjects appear over-bright, or “washed out.”

Taking Pictures in Scene Mode

SCENE (scene) mode offers a menu of fifteen “scenes,” each corresponding to a common situation, such as a backlit subject, sunset, or interior shot. Camera settings are automatically adjusted to suit the selected scene, sparing the user the necessity of adjusting each setting separately.

Scene	Description	
 Portrait	Use for portraits in which the main subject stands out clearly while background details are softened.	39
 Party/Indoor	Use to capture background details or the effects of candlelight and other indoor lighting.	39
 Night portrait	Use for portraits taken against a dimly-lit backdrop.	39
 Beach/Snow	Use for bright subjects such as snowfields, beaches, and sunlit expanses of water.	39
 Landscape	Use to enhance outlines, colors, and contrast in skylscapes, forests, and other landscape shots.	40
 Sunset	Use to preserve the deep hues seen in sunsets and sunrises.	40
 Night landscape	Use when taking landscape shots at night.	40
 Museum	Use where flash photography is prohibited.	41
 Fireworks show	Use to capture the expanding burst of light from a firework.	41
 Close up	Use to capture vivid colors in close-up shots of flowers, insects, and other small objects.	41
 Copy	Use to copy text and line drawings.	42
 Back light	Use when light is coming from behind the subject, throwing their features into shadow.	42
 Panorama assist	Use to take a series of pictures that will later be joined on a computer to form a panorama.	42
 Sports	Use for sports shots that freeze motion in rapidly-moving subjects.	43
 Dusk/Dawn	Use to preserve the colors seen in the weak natural light before sunrise and after sunset.	43

Shooting in Scene Mode

Turn the monitor on before shooting in scene mode.

Taking Pictures in Scene Mode

To select a scene:

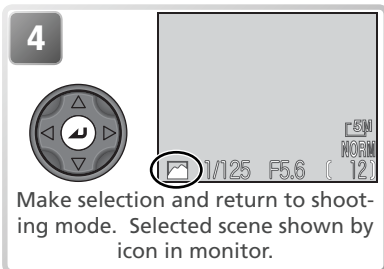
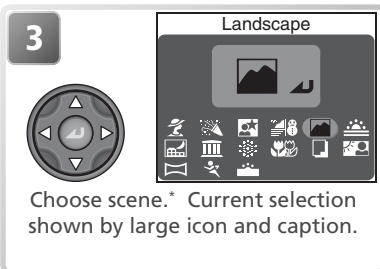
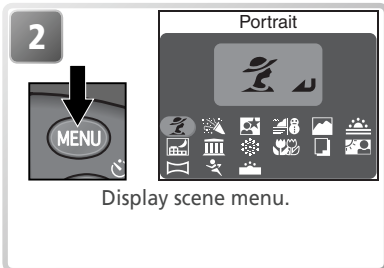
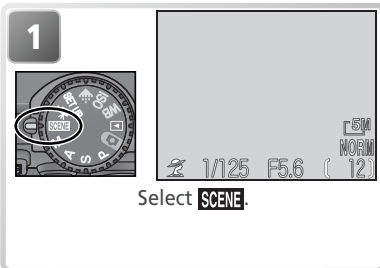

* Scene can also be selected by rotating command dial. Press **MENU** button to exit without changing current selection.

Depending on the scene selected, restrictions may apply to flash (⚡; 32) or focus mode (AF; 34). These restrictions are noted on the pages that follow.

Camera Shake

At slow shutter speeds, pictures may be blurred. In this section, precautions appropriate for avoiding blur are indicated by stars:

- ★ hold camera in both hands and brace elbows against body
- ★★ use tripod or rest camera on flat, level surface

Autofocus (**SCENE** Mode)

In **SCENE** mode, the camera focuses continuously until the shutter-release button is pressed halfway.

The following scenes are available:

Portrait



Use for portraits. Main subject stands out clearly while background details are softened, lending composition sense of depth.

- Degree of softening depends on amount of light available.
- Focus area can be selected manually using multi selector (👁️ 70).

  (other modes can be selected)  Auto (other modes can be selected)

Party/Indoor



Use for shots that include details of the background, or to capture the effects of candlelight and other indoor background lighting. 



  (other modes can be selected)  Auto (other modes can be selected)

Night portrait



Use for shots that provide natural balance between main subject and background when shooting portraits under low light. 

Noise reduction (👁️ 40) turns on automatically at slow shutter speeds.

   Auto (🔄 can be selected)

Beach/Snow



Captures the brightness of such subjects as snowfields, beaches, or sunlit expanses of water.

 Auto (other modes can be selected)  Auto (other modes can be selected)

Taking Pictures in Scene Mode

Landscape



Use for vivid landscape shots that enhance outlines, colors, and contrast in such subjects as skyscapes and forests.

Focus is fixed at infinity, eliminating the need to check focus before shooting.



 (☺ can be selected)

Sunset

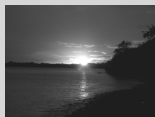

Preserves the deep hues seen in sunsets and sunrises.



(other modes can be selected)



Auto (☺ can be selected)

Night landscape



A slow shutter speed is used to produce stunning night landscapes.



- Noise reduction turns on automatically at slow shutter speeds.
- Focus is fixed at infinity, eliminating the need to check focus before shooting.



 (☺ can be selected)

Noise Reduction



“Noise” in the form of randomly-spaced, brightly-colored pixels tends to appear in pictures taken at slow shutter speeds. This effect is particularly noticeable in dark areas of the picture. At settings of **Night portrait**, **Night landscape**, and **Dusk/Dawn**, pictures taken at shutter speeds of about $\frac{1}{4}$ s or slower are processed to reduce noise (this more than doubles the time needed to process pictures before they are saved to the memory card). **NR** is displayed in the monitor when noise reduction is in effect.

Museum

Use indoors where flash photography is prohibited (for example, in museums and art galleries) or in other settings in which you do not want to use the flash. ★

- The Best Shot Selector (BSS;  97) turns on automatically, reducing the effects of inadvertent camera movement.
- Photography may be prohibited altogether in some settings. Be sure to obtain permission first.



Auto  and  can be selected

Fireworks show



Slow shutter speeds are used to capture the expanding burst of light from a firework. ★ ★

Focus is fixed at infinity, eliminating the need to check focus before shooting.



Close up



Use to capture vivid colors in close-up shots of flowers, insects, and other small objects, with the background artistically blurred. ★

- Minimum focus distance varies with zoom position. To focus on objects as close as 1 cm/0.4" to the lens, adjust zoom until the macro close-up icon  in monitor turns green.
- Focus area can be selected manually using multi selector ( 70).



 (other modes can be selected)



  can be selected

Taking Pictures in Scene Mode

Copy



Provides clear pictures of text or drawings on a white board or in printed matter such as a business card.





- Use macro close-up ( 34) to focus on objects close to the camera.
- Colored text and drawings may not show up well in the final picture.

  (other modes can be selected)  Auto (other modes can be selected)

Back light



Use when light is coming from behind the subject, throwing their features into shadow, or when the subject is in the shade but the background is brightly lit. The flash will fire automatically to “fill in” (illuminate) shadows.

   Auto ( can be selected)

Panorama assist



Use to take a series of pictures that will later be joined to form a single scene (e.g., a panorama or 360° virtual-reality image). See “Taking Pictures for a Panorama” ( 44).

- Auto white balance and exposure are determined by the first picture in each series.
- Flash and focus mode can not be changed after shooting begins.
- Each series of pictures is stored in a separate folder with a name consisting of a folder number, “P_”, and a three-digit sequence number assigned automatically by the camera (e.g., “101P_001”).

  (other modes can be selected)  Auto (other modes can be selected)

 Sports

High shutter speeds freeze motion for dynamic sports shots.

- Monitor turns off during shooting. Frame pictures in viewfinder.
- Camera records pictures at about three frames per second while shutter-release button is fully pressed.
- Focus, exposure, and auto white balance are determined by the first picture in each series.



Auto (other modes can be selected)

 Dusk/Dawn

Preserves the colors seen in the weak natural light before sunrise or after sunset.



- Noise reduction ( 40) turns on automatically at slow shutter speeds.
- Focus is fixed at infinity, eliminating the need to check focus before shooting.



can be selected)

 Scene Mode

Depending on your subject, scene mode may not always produce the desired results. If results are not satisfactory, choose  (auto), **P**, **S**, **A**, or **M** mode and try again.

Taking Pictures for a Panorama

1



Highlight  (Panorama assist).

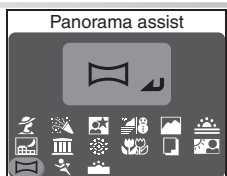

2



Default pan direction displayed in monitor.

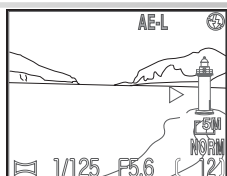

3



Right to left

Top to bottom

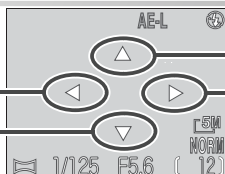

Bottom to top

Left to right

Select how pictures will be joined together in completed panorama. This is the direction in which to pan the camera after each shot. Yellow AE-L icon in monitor shows that white balance and exposure will lock with first shot.

4



Take first picture. About one third of picture is shown superimposed on view through lens. If pan direction is left to right, picture will appear on left side of monitor. AE-L icon turns white to show that white balance and exposure settings for this picture apply to all pictures in series.

Panorama Assist

The pan direction, flash mode, and focus mode can not be changed after the first picture is taken. Shooting will end if the monitor is closed.

Use a Tripod

Using a tripod makes it easier to compose overlapping shots.



5

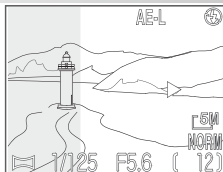

Compose next shot to overlap with previous picture.

6

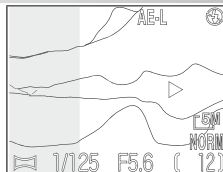

Take next picture. Repeat steps 5–6 until all shots in series have been taken.

7



End series.

Viewing Pictures Taken Using Panorama Assist

To view pictures taken at a setting of **Panorama assist**, select **All folders** in the playback **Folders** menu, or select the appropriate folder from the folder list (118).

More on Photography

“Basic Photography” introduced the basics of taking pictures in  (auto) and **SCENE** (scene) modes. This chapter explains some of the more frequently-used camera functions in greater detail, and describes how to take pictures in **P**, **S**, **A**, and **M** modes.

Controlling Exposure		48
Image Quality and Size		54
Sensitivity		58
White Balance		60
Continuous		63
Sharpening, Contrast, and Color		65
Metering		68
More on Focus		69

Controlling Exposure

 In **(auto)** and **SCENE** (scene) modes, the camera automatically adjusts shutter speed and aperture to produce optimal exposure. In **P**, **S**, **A**, and **M** modes, shutter speed and aperture can be adjusted to suit the user's creative intent.

Mode	How it works	When to use it
P Programmed auto	Camera sets shutter speed and aperture for best exposure. Flexible program can be used to select additional combinations of shutter speed and aperture that will produce the same exposure.	Best choice in most situations.
S Shutter-priority auto	User chooses shutter speed; camera sets aperture for best results.	High shutter speeds freeze action. Low shutter speeds suggest movement by blurring moving objects.
A Aperture-priority auto	User chooses aperture; camera sets shutter-speed for best results.	Large apertures (small f-numbers) soften background details and let more light into camera, increasing range of flash. Small apertures (large f-numbers) increase depth of field, bringing main subject and background into focus.
M Manual	User controls both shutter speed and aperture.	Use when you want complete control over exposure.

P: Programmed Auto

In programmed auto, the camera automatically adjusts shutter speed and aperture according to the amount of light available, producing optimal exposure in most situations. Adjustments to exposure can be made using exposure compensation (☒ 36) or exposure bracketing (☒ 109).

Flexible Program

In programmed auto, different combinations of shutter speed and aperture can be selected by rotating the command dial (flexible program). Each combination of shutter speed and aperture will produce the same exposure.

1

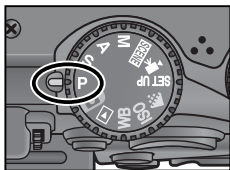

Select mode P.

2

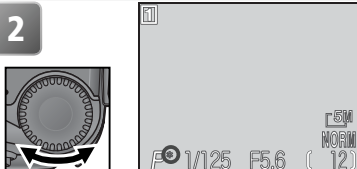

Shutter speed and aperture shown in monitor. Asterisk ("*") appears when flexible program is in effect.

☒ Restoring Default Values for Shutter Speed and Aperture

Default values for shutter speed and aperture can be restored by rotating the command dial until the asterisk ("*") is no longer displayed. Default values can also be restored by selecting another mode or turning the camera off.

S: Shutter-Priority Auto

In shutter-priority auto, the user selects the shutter speed by rotating the command dial; aperture is set automatically by the camera in response to lighting conditions. Shutter speed can be set to values between 8 s and $\frac{1}{4000}$ s in increments equivalent to 1 EV (one step).

1

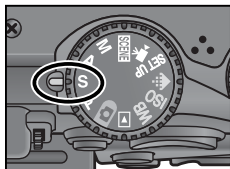

Select mode S.

2

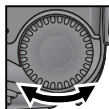

Shutter speed displayed in monitor.

If the selected shutter speed would result in the picture being under- or over-exposed, the shutter speed display in the monitor will flash when the shutter-release button is pressed halfway. Choose another shutter speed and try again. At slow shutter speeds, the shutter-speed indicator in the monitor will turn yellow to show that “noise” in the form of randomly-spaced, brightly-colored pixels may appear in the final photograph. We recommend that you either choose a faster shutter speed or use noise reduction (111).

Ultra HS

When **Ultra HS** is selected in the **Continuous** menu (63), the frame advance rate is fixed at thirty frames per second, with the result that shutter speed can not be set to a value slower than $\frac{1}{30}$ s.

Faster Shutter Speeds

When a shutter speed of $\frac{1}{4000}$ s is selected in shutter-priority auto, aperture is restricted to values between f/4.4 and f/7.9 when the camera is zoomed all the way out, or to f/7.3 when the camera is zoomed all the way in. If you are unable to achieve optimum exposure in shutter-priority auto, choose aperture-priority auto (exposure mode **A**), zoom the camera all the way out, and select the smallest aperture (largest f/-number). Depending on the amount of light available, it may be possible to achieve optimum exposure at shutter speeds as fast as $\frac{1}{4000}$ s ($\frac{1}{8000}$ s in **Ultra HS** mode).

A: Aperture-Priority Auto

In aperture-priority auto, aperture is controlled by rotating the command dial; shutter speed is set automatically by the camera in response to lighting conditions. Aperture varies in increments equivalent to $\frac{1}{3}$ EV ($\frac{1}{3}$ step); depending on the zoom position you may be able to achieve apertures as large as f/5 or as small as f/8.

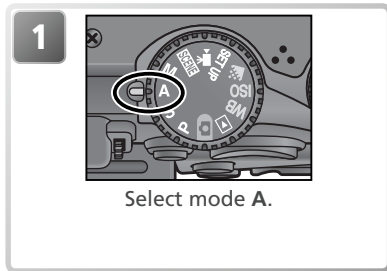

Select mode A.

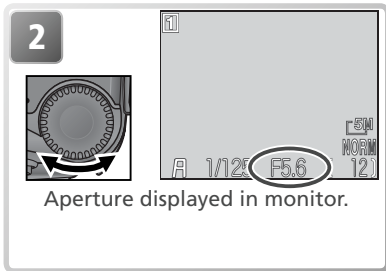

Aperture displayed in monitor.

If the selected aperture would result in the picture being under- or over-exposed, the aperture display in the monitor will flash when the shutter-release button is pressed halfway. Choose another aperture and try again.

An aperture of f/8 may not be available at some zoom positions. For smaller apertures, try zooming the camera out.

Aperture and Zoom

The maximum and minimum values for aperture are the maximum and minimum values for the camera lens, adjusted for the current zoom setting. Higher f-numbers (smaller apertures) can be achieved by zooming the camera in, lower f-numbers (larger apertures) by zooming the camera out. Unless **On** is chosen for **Zoom options > Fixed aperture** in the shooting menu ( 105), aperture will change as the camera is zoomed in or out. If the second-highest aperture setting is selected with the camera zoomed all the way out and the camera is then zoomed in, the camera will vary the f-number to maintain aperture at the second-highest setting for the current zoom position.

M: Manual

In manual exposure mode, the user controls both shutter speed and aperture. Shutter speed can be set to values between 8s and $\frac{1}{4000}$ s in increments equivalent to 1 EV (one step), or the shutter can be held open for long time-exposures of up to ten minutes (see opposite page). Aperture can be set to values between the minimum and maximum in increments equivalent to $\frac{1}{3}$ EV ($\frac{1}{3}$ step).

1

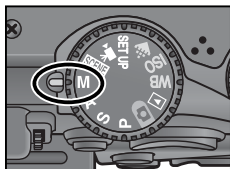

Select mode M.

2

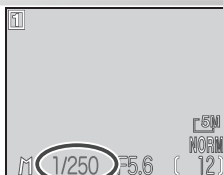

Select shutter speed or aperture. Selected item (shown in green) changes each time button is pressed.

3

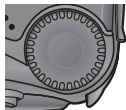

Set selected item. Exposure display shows amount picture will be under- or over-exposed at selected setting.

4

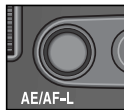

Select remaining item (aperture or shutter speed).

5

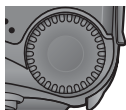

Set selected item. Repeat steps 2–3 until desired exposure is achieved.

If the Shutter Speed Is Displayed in Red

If the selected shutter speed exceeds the limits of the camera's exposure control system, the shutter speed will be displayed in red and no pictures can be taken.

Understanding the Exposure Display

The exposure display in the monitor shows the amount pictures will be under- or overexposed at the values currently selected for shutter speed and aperture. The amount exposure deviates from the value suggested by the camera is shown in EVs (-2 to +2 EV) in increments of $\frac{1}{3}$ EV).

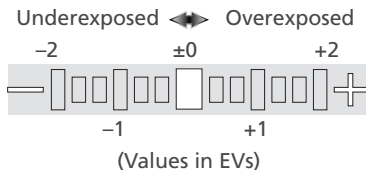

Long Time-Exposures

When **Single** is selected for **Continuous** (63) in manual exposure mode, the shutter can be left open for long time-exposures of up to ten minutes. With shutter speed selected in the monitor, rotate the command dial until the shutter-speed display shows BULB or TIME. The length of time the shutter will remain open depends on the option selected for **Exposure options > Bulb/Time** in the shooting menu (104):

- **Bulb release:** The shutter will remain open as long as the shutter-release button is held down, to a maximum of ten minutes. Shutter-speed display shows BULB10M.
- **Timed release:** Select this option for time exposures of thirty seconds, one minute, three minutes, five minutes, or ten minutes. The shutter will open when the shutter-release button is pressed and remain open until the exposure is complete or the shutter-release button is pressed a second time. Shutter-speed display shows TIME and the selected exposure time (e.g., "TIME30S").



To prevent blurring caused by camera shake, we recommend using a tripod and a remote shutter release such as the MC-EU1 remote cord. To reduce "noise" in the form of randomly-spaced, brightly-colored pixels, use noise reduction (111).

Image Quality and Size

Together, image quality and size determine how much space each picture occupies on the memory card.

More on Photography

Image Quality

The camera stores pictures in one of two formats: TIFF (HI quality) and JPEG (FINE, NORMAL, and BASIC quality). JPEG images are compressed to reduce the amount of memory each picture occupies. Images are analyzed in blocks eight pixels on a side and detail within each block selectively reduced. The more images are compressed, the smaller the resulting files and the less space occupied on the memory card. Compressing images to make very small files may however cause the block pattern to become visible, and there may also be noticeable loss of detail. The actual effects depend on the type of subject and the size of the image when printed or displayed.







Option	Format	Description	Compression
HI	TIFF (RGB)	Image stored in TIFF (Tagged Image File Format) with no compression. Use when fidelity is of paramount importance. Only available at image sizes of $5M$ (2592 × 1944) and 3.2 (2592 × 1728).	None
FINE	JPEG	Fine image quality, suitable for enlargements or high quality prints. File size reduced to roughly $\frac{1}{4}$ of original.	 Low
NORMAL		Normal image quality, suited to most applications. File size reduced to roughly $\frac{1}{8}$ of original.	
BASIC		Basic image quality, suitable for pictures that will be distributed by e-mail or used in web pages. File size reduced to roughly $\frac{1}{16}$ of original.	

Digital Zoom

Digital zoom is not available at HI image quality.

Image Size

Image size refers to the physical dimensions of the picture, measured in pixels. Pictures taken at smaller sizes require less memory to store, making them suited to distribution by e-mail and the web. Conversely, the larger the image, the larger the size at which it can be printed or displayed without becoming noticeably “grainy.” Choose an image size according to the space available on the memory card and the task at hand.

Option	Description
 2592 × 1944	Will print at a size of about 21.9 × 16.5 cm (8½” × 6½”).*
 1600 × 1200	Will print at a size of about 13.5 × 10.2 cm (5½” × 4”).*
 1280 × 960	Will print at a size of about 10.8 × 8.1 cm (4” × 3”).*
 1024 × 768	Suited to printing at smaller sizes (for example, as in illustration in a letter or report), or to display on monitors 17” or larger.
 640 × 480	Can be displayed full screen on 13” monitors. Suited to distribution by e-mail or the web.
 2592 × 1728	The top and bottom of the frame are cropped out to produce a picture of the same proportions as photographs taken with a 35-mm film camera. The green (AF) lamp blinks slowly to show that pictures can not be accurately framed in the viewfinder.

* Assumes a printer resolution of 300 dpi.

Print Size

The size of images when printed depends on the printer resolution: the higher the resolution, the smaller the final print size.

Image Quality and Size

To choose image quality or size:

More on Photography

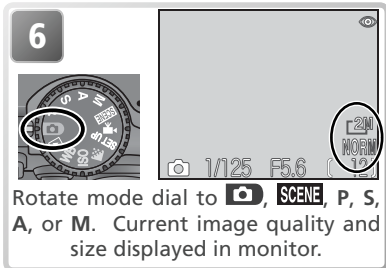
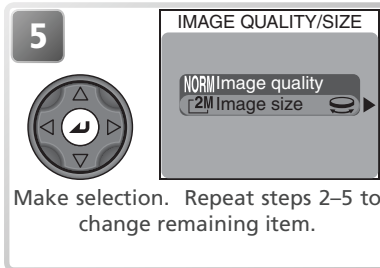
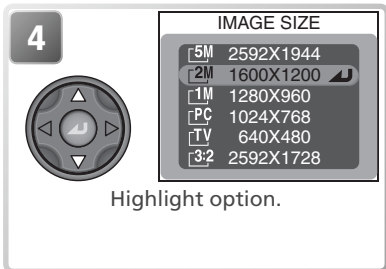
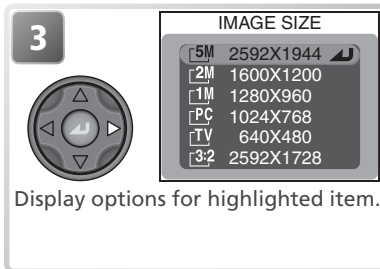
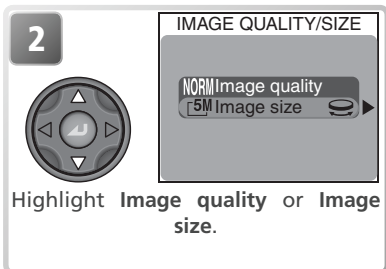







The Shooting Menu

Image quality and size can also be set using the **Image quality/size** option in the shooting menu (94).

Memory Card Capacity and Image Quality/Size

The approximate number of pictures that can be stored on 16MB, 64MB, and 96MB cards at different combinations of image quality and size is shown below.

Card	Image quality	Image size					
		 5M 2592 × 1944	 2M 1600 × 1200	 1M 1280 × 960	 PC 1024 × 768	 TV 640 × 480	 3:2 2592 × 1728
16 MB	HI	1	—	—	—	—	1
	FINE	6	16	24	37	86	7
	NORMAL	12	31	47	69	144	14
	BASIC	24	59	86	121	229	27
64 MB	HI	4	—	—	—	—	4
	FINE	25	65	100	151	347	28
	NORMAL	50	125	190	278	578	56
	BASIC	97	236	347	488	918	109
96 MB	HI	6	—	—	—	—	7
	FINE	38	97	150	227	520	42
	NORMAL	75	188	285	418	867	84
	BASIC	146	354	520	731	1377	163

* All figures are approximate. File size of JPEG images varies with scene recorded.

Sensitivity (P, S, A, and M)

Sensitivity is a measure of how quickly the camera reacts to light. The higher the sensitivity, the less light needed to make an exposure, allowing the same exposure to be achieved with faster shutter speeds or smaller apertures. In a film camera, sensitivity is a characteristic of the film, not the camera. The ISO ratings on film packages are a measure of sensitivity—the higher the ISO rating, the more sensitive the film. Higher sensitivity is achieved by altering the chemical composition of the film, causing a random pattern, called “grain,” to appear in the final picture. In a digital camera, increased sensitivity has a similar effect: higher sensitivities allow higher shutter speeds, at the expense of “noise”—randomly spaced, brightly colored pixels that appear mainly in dark parts of the image.

In  (auto) and **SCENE** (scene) modes, the camera automatically raises sensitivity when lighting is poor. In **P**, **S**, **A**, and **M** modes, the following options are available:

Option	Description
50	Approximately equivalent to an ISO rating of 50. Recommended except when lighting is poor or when faster shutter speeds are required (e.g., when photographing moving objects). Noise may appear in pictures taken at ISO settings above this value.
100	Approximately equivalent to an ISO rating of 100.
200	Approximately equivalent to an ISO rating of 200.
400	Approximately equivalent to an ISO rating of 400.
Auto	Equivalent to a setting of 50 under normal conditions; when lighting is poor, however, camera automatically compensates by raising sensitivity to a maximum equivalent to ISO 200.

Auto

In  and **SCENE** modes, or when a sensitivity of **Auto** is selected in **P**, **S**, **A**, or **M** mode, an **ISO** icon is displayed in the monitor whenever sensitivity is raised above ISO 50 equivalent. Noise may appear in pictures taken when this icon is displayed.

Noise Reduction

Noise reduction ( 111) can be used to reduce noise in pictures taken at shutter speeds of about 1/4 s or slower.

To choose a value for sensitivity:

1



SENSITIVITY menu displayed.

2



Make selection.

3

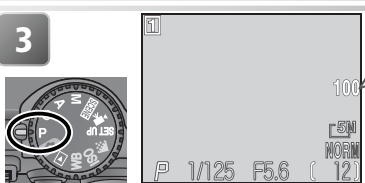

Rotate mode dial to P, S, A, or M. At settings other than Auto, ISO value is displayed in monitor.

Exposure Mode

If **Auto** is selected in shutter-priority auto or manual exposure mode, sensitivity will be fixed at ISO 50 equivalent and will not vary with lighting conditions.

Using the Flash

A setting of **400** is intended for use with natural lighting. Choose **Auto, 50, 100,** or **200** when using the flash.







The Shooting Menu

Sensitivity can also be set using the **Sensitivity** option in the shooting menu (94).

White Balance (P, S, A and M)

The color of the light reflected from an object varies with the color of the light source. The human brain is able to adapt to such changes in color, with the result that we see white objects as white, regardless of whether they are in the shade, direct sunlight, or under incandescent lighting. Unlike the film used in film cameras, digital cameras can mimic this adjustment by processing information from the camera's image sensor (CCD) according to the color of the light source. This process is known as a "white balance adjustment."

In  and **SCENE** modes, white balance is adjusted automatically to suit the selected scene. In **P**, **S**, **A**, and **M** modes, you can choose from the following white balance options:

Option	Description
A-WB Auto	White balance adjusted automatically to suit lighting conditions. Best choice in most situations.
PRE White bal preset	White object used as a reference to set white balance under unusual lighting conditions.
 Daylight	White balance adjusted for direct sunlight.
 Incandescent	White balance adjusted for incandescent lighting.
 Fluorescent	White balance adjusted for fluorescent lighting.
 Cloudy	Use when shooting outdoors under cloudy skies.
 Speedlight	White balance adjusted for light produced by built-in flash.
 Shade	Use under sunny skies when your subject is in the shade.

To choose a white balance setting:

1



WHITE BALANCE 1/2

- A-WB Auto
- PRE White bal preset**
- Daylight
- Incandescent
- Fluorescent
- Cloudy
- Speedlight

WHITE BALANCE menu displayed.

2



WHITE BALANCE 1/2

- A-WB Auto
- PRE White bal preset**
- Daylight
- Incandescent
- Fluorescent
- Cloudy
- Speedlight

Make selection. (To fine-tune white balance, rotate command dial. See following page.)

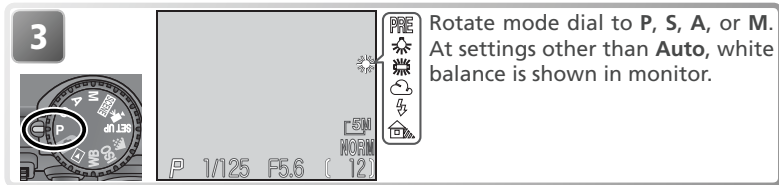

Fine-Tuning White Balance

At settings other than **A-WB (Auto)** and **PRE (White bal preset)**, white balance can be “fine tuned” to compensate for variations in the color of the light source or to create pictures with a “warm” or “cold” cast. Except in the case of  (**Fluorescent**), adjustments can be made in the range +3 to -3 in increments of one. Higher settings can be used to lend images a bluish tinge or to compensate for light sources with a yellow or red cast. Lower settings can be used to make pictures slightly yellow or red or to compensate for light sources with a blue cast.

When white balance is set to  (**Fluorescent**), you can choose from three different bulb types (see table at right).

To fine-tune white balance, display the white-balance menu and highlight an option as described above, then follow the steps below:

Option	Bulb type
FL1	White (W)
FL2	Daylight White/ Neutral (N)
FL3	Daylight (D)

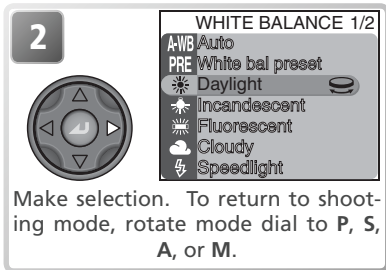
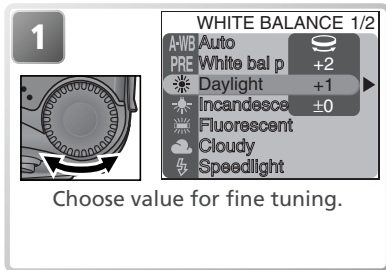

Preset White Balance

More on Photography

Preset white balance is used when shooting under mixed lighting or to compensate for light sources with a strong color cast (for example, to make pictures taken under a lamp with a red shade look as though they had been taken under white light). If the multi selector is pressed to the right when **PRE** **White bal preset** is selected in the white-balance menu, the camera will zoom in and the menu shown above at right will be displayed in the monitor.

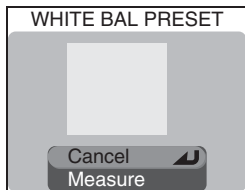

Option	Description
Cancel	Recalls the most recent value for preset white balance from the memory and sets white balance to this value.
Measure	To measure a new value for white balance, place a white object, such as a piece of paper, under the lighting that will be used in the final picture. Frame this object so that it fills the square in the center of the menu shown above. Highlight Measure and press the center of the multi selector to measure a new value for white balance (shutter will be released and camera will return to original zoom position, but no picture will be recorded).







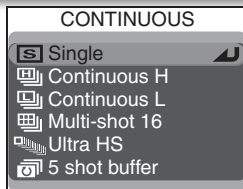

The Shooting Menu

White balance can also be set using the **White balance** option in the shooting menu ( 94).

Continuous (P, S, A, and M)

In **P**, **S**, **A**, and **M** modes, the **Continuous** option in the shooting menu can be used to take pictures in a rapid sequence. This can be used to capture fleeting expressions on a portrait subject, photograph a subject that is moving unpredictably, or capture motion in a series of pictures.



Option	Description
 Single	One shot recorded each time shutter-release button is pressed.
 Continuous H	Camera records pictures at up to three frames per second while shutter-release button is pressed, to a maximum of seven shots. Monitor turns off during shooting; frame pictures in viewfinder.
 Continuous L	Camera records pictures at up to 1.5 fps (three frames every two seconds) while shutter-release button is pressed. Rate of recording will drop when  (wait) icon is displayed.
 Multi-shot 16	Each time shutter-release button is pressed, camera takes sixteen consecutive pictures 648 × 486 pixels in size at rate of about 2 fps and arranges them in four rows to form a single picture measuring 2592 × 1944 pixels. Only available at image size of  2592 × 1944 .
 Ultra HS	Camera records pictures 320 × 240 pixels in size while shutter-release button is pressed. Shooting stops after one hundred pictures or when shutter-release button is released. Image quality is set to NORMAL, allowing pictures to be taken at up to 30 fps. With each sequence, camera creates new folder in which all photos in sequence are stored. Folder name consists of "N_" followed by three-digit number assigned automatically by camera. Exposure count is shown in monitor.
 5 shot buffer	Camera records pictures at up to 1.5 fps (three frames every two seconds) while shutter-release button is pressed, but only last five pictures are recorded to memory card.

HI Image Quality

Options other than **Single** are not available when HI is selected for image quality.

Using the Menus

For more information on menu operations, see "Using the Menus" ( 10).

Continuous

Using a Flash

At settings other than **Single**, the built-in Speedlight turns off automatically and will not fire even when lighting is poor. Optional Speedlights mounted on the accessory shoe can be used at settings other than **Ultra HS**.

Focus, Exposure, and White Balance

At settings other than **Single**, focus, exposure, and white balance are determined by the first picture in each series.



Digital Zoom

Digital zoom is not available at settings of **Multi-shot 16** and **Ultra HS**.

Noise Reduction 111

Noise reduction can not be used in combination with settings other than **Single**.

Ultra HS

Ultra HS can not be used in combination with BSS  97) or bracketing  109). If the monitor is swivelled to point in the same direction as the lens during shooting, the display in the monitor will be inverted.

During shooting, the zoom indicator in the monitor will move from **S** (start) to **E** (end). To interrupt shooting before one hundred pictures have been recorded, lift your finger from the shutter-release button.

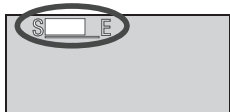

The Memory Buffer

During shooting, pictures are stored in a temporary memory buffer before being transferred to the memory card for permanent storage. You can continue to take pictures as long as room is available in the buffer. When the buffer is full, a  (wait) icon will be displayed and shooting will be suspended. More pictures can be taken as soon as enough memory becomes available in the buffer.

Continuous

At settings other than **Single**, the current “continuous” setting is shown by an icon in the monitor when the camera is in **P**, **S**, **A**, or **M** mode.

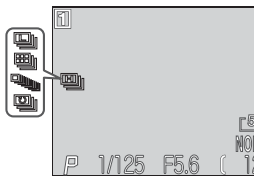

Sharpening, Contrast, and Color (P, S, A, and M)

In **P**, **S**, **A**, and **M** modes, the shooting menu (94) offers options for sharpening outlines, improving contrast, and adjusting color during shooting. Options can be chosen to suit the subject or according to how the picture will be used.

Image Sharpening

In **VIDEO** and **SCENE** modes, the camera automatically processes pictures to emphasize the borders between light and dark areas of the picture, making edges seem sharper. As this processing takes place after shooting, its effects can not be previewed in the monitor, but they will be visible in the final picture. In **P**, **S**, **A**, and **M** modes, the image-sharpening menu gives you control over the amount of sharpening performed.

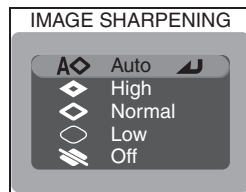

Option	Description
A Auto	Camera sharpens edges for optimal results; amount of sharpening varies from shot to shot.
H High	Pictures processed to increase sharpness, making edges more distinct.
N Normal	Camera performs same standard level of sharpening on all images.
L Low	Sharpening reduced below normal level.
Off	No sharpening performed.

Image Adjustment

More on Photography

In **📷** and **SCENE** modes, the camera automatically adjusts contrast for optimal results before recording pictures to the memory card. In **P**, **S**, **A**, and **M** modes, the image-adjustment menu grants control over contrast.

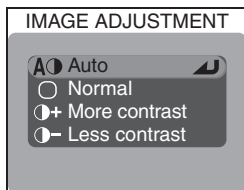

Option	Description
A <input checked="" type="radio"/> Auto	Camera automatically adjusts contrast according to shooting conditions.
<input type="radio"/> Normal	Camera performs same standard contrast adjustment on all pictures. Suitable for a wide variety of scenes, from dark to bright.
<input checked="" type="radio"/> More contrast	Picture processed to emphasize difference between light and dark areas, enhancing contrast. Useful when shooting under overcast skies or shooting low contrast subjects such as landscapes.
<input type="radio"/> Less contrast	Picture processed to decrease difference between light and dark areas, reducing contrast. Recommended when light is very bright, creating strong shadows on subject.

Image Adjustment

At settings other than **Auto**, the current image-adjustment setting is indicated by an icon in the monitor when the camera is in **P**, **S**, **A**, or **M** mode.

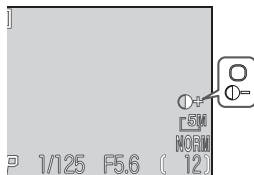

Saturation Control

Saturation control is used to heighten or reduce the vividness of colors.

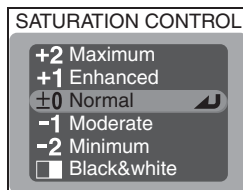

Option	Description
+2 Maximum	Use for vivid, photoprint effect when taking pictures that will be printed "as is," without further modification.
+1 Enhanced	
0 Normal	Best choice in most situations.
-1 Moderate	Use when taking pictures that will later be retouched on a computer.
-2 Minimum	
<input type="checkbox"/> Black&white	Pictures recorded in black-and-white. Black-and-white images require same amount of memory as color images, but show a higher level of detail. Black&white can not be used in combination with digital zoom, white balance, white-balance bracketing, or a Lens setting of Slide copy adptr.

Black-and-White



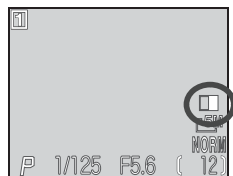

When **Black&white** is selected, monitor shows the view through the lens in black-and-white. A icon appears in the monitor when the camera is in **P**, **S**, **A**, or **M** mode.

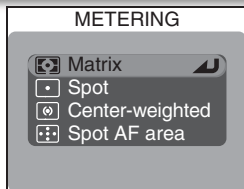

Metering (P, S, A, and M)

In **P**, **S**, **A**, and **M** modes, the metering menu offers a choice of four metering methods for determining how the camera sets exposure (in **▶** and **SCENE** modes, matrix metering is used). Choose a metering method suited to the composition and lighting conditions.



Option	How it works	When to use it
 Matrix	Camera compares measurements from 256 areas of frame with library of typical compositions to produce optimal exposure for entire picture.	Best choice in most situations.
 Spot	Camera meters area shown by square in center of monitor. Only about 1/32 of frame is metered.	Ensures that subject in metering target will be correctly exposed even when background is much brighter or darker. Can be used with autoexposure lock (🔒 30) to meter off-center subjects.
 Center-weighted	Camera meters entire frame but assigns weight of 80% to area in center of frame occupying roughly 1/4 of total.	Classic meter for portraits; preserves background details while letting lighting conditions at center of frame determine exposure. Can be used with autoexposure lock (🔒 30) to meter off-center subjects.
 Spot AF area	Camera meters active focus area when Manual or Auto selected for Focus options > AF area mode (🔒 69).	Links spot metering to active focus area. Use instead of autoexposure lock to meter off-center subjects. Matrix metering is used when focus-area selection is off; if monitor is off, spot metering is used.

Metering

At settings other than **Matrix**, the current metering method is indicated by an icon in the monitor.

Spot metering exposure target

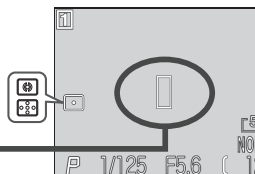

More on Focus (P, S, A, and M)

Focus Options

The **Focus options** item in the shooting menu for **P**, **S**, **A**, and **M** modes (📷 94) contains three options controlling focus settings.

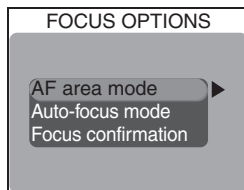

AF Area Mode

In  (auto) mode (and at all scene-mode settings except **Portrait** and **Close up**), the camera automatically focuses on the subject in the focus area at the center of the frame, shown by the focus brackets in the viewfinder. In **P**, **S**, **A**, and **M** modes, a total of five focus areas are available, making it possible to focus on an off-center subject without using focus lock. **AF area mode** determines how the focus area is selected.

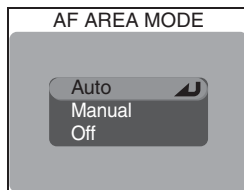

Option	Description
Auto	Camera automatically selects focus area containing subject closest to camera. Selected focus area is displayed in red when shutter-release button is pressed halfway. Choose this setting to minimize risk of pictures being out of focus when subject is moving erratically or in other situations in which there is little time to check focus.
Manual	User selects focus area manually using multi selector. Can be used instead of focus lock (📷 29) to focus on relatively motionless subjects that are not centered in frame.
Off	Camera focuses on subject in center focus area (shown by focus brackets in viewfinder). No focus area indicators appear in monitor. Can be used in combination with focus lock (📷 29) to focus on off-center subjects.

Restrictions on Focus Area Selection

Focus-area selection is not available when the monitor is off or digital zoom (📷 26) is in effect. In these cases, the center focus area is used.

 *Manual Focus Area Selection*

When **Manual** is selected for **AF area mode**, five focus areas are displayed in the monitor. Press the multi selector up, down, left, or right to select the focus area containing your subject. Manual focus area selection can be used in combination with focus lock ( 29) if the subject does not fall in any of the five focus areas.



 *Spot AF Area Metering*

Focus area selection (both manual and automatic) can be used in combination with spot AF-area metering to meter exposure only in the active focus area ( 68).

Auto-Focus Mode

In **P**, **S**, **A**, and **M** modes, the **Auto-focus mode** option determines how the camera focuses when the monitor is on (single autofocus is used when the monitor is off, regardless of the setting chosen for **Auto-focus mode**).

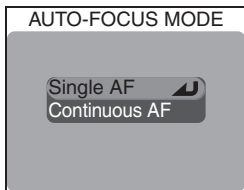

Option	Description
Single AF	Camera focuses when shutter-release button is pressed halfway. If monitor is off, pictures can only be taken when camera is in focus. Choose this option to save batteries. Note that when monitor is on, pictures can be taken even if camera is not in focus; check green (AF) lamp before shooting.
Continuous AF	Camera adjusts focus continuously until shutter-release button is pressed halfway, minimizing time needed to focus before picture is taken. Note that pictures can be taken even when camera is not in focus; check green (AF) lamp before shooting.

Focus Confirmation

Use focus confirmation to determine exactly what areas of the frame are in focus before a picture is taken. Focus confirmation affects only the view through the lens shown in the monitor; no indicators of focus appear in the final picture.

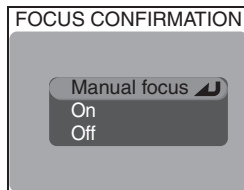

Option	Description
Manual focus	Areas of the image that are in focus will be sharply outlined in monitor in manual focus mode (72).
On	Areas of the image that are in focus will be sharply outlined in monitor in all focus modes (34).
Off	No indication of focus appears in monitor.

Manual Focus

In **P**, **S**, **A**, and **M** modes, manual focus is available for situations in which you can not achieve the desired results using autofocus. The focus distance can be selected from preset values ranging from 1 cm (0.4') to infinity. To use manual focus:

1

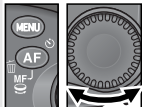

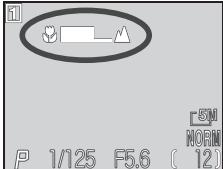

Pressing MF (AF) button, rotate command dial until subject is in focus. Manual focus display shows approximate focus distance (from lens), from 1 cm/0.4' (🌸) to infinity (▲).

2

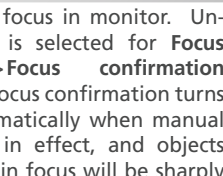

Confirm focus in monitor. Unless **Off** is selected for **Focus options > Focus confirmation** (71), focus confirmation turns on automatically when manual focus is in effect, and objects that are in focus will be sharply outlined in monitor.

3



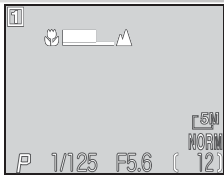

Take pictures. To cancel manual focus, press MF (AF) button to select another focus mode.

Close-Ups

Minimum focus distance varies with zoom position. At some zoom positions, the camera may be unable to focus at very short distances (the 🌸 end of the manual focus display). If the camera is unable to focus at the current zoom position, the manual focus display will turn red.

Focus Lock

Focus can not be locked using the AE/AF-L button in manual focus mode.

Using a Converter Lens

Use autofocus (73) when using an optional converter lens (74).

More on Playback

This chapter describes how to view pictures on the camera, on television, and on a computer.

Viewing Pictures on the Camera.....  **74**

Viewing Pictures on TV.....  **82**

Viewing Pictures on a Computer  **83**

Printing Pictures  **86**

Viewing Pictures on the Camera

This section describes how to view pictures on the camera, both full-screen and as thumbnails, how to zoom in on pictures for a closer look, record voice memos, and create small copies of your pictures.

More on Playback

Quick Review and Playback

There are two ways to play pictures back on the camera: quick review, in which you can view your pictures without leaving shooting mode, and a dedicated playback mode that can be used to view movies, create small copies of still pictures, or access the options in the playback menu.

Quick Review

Quick review is used to play back pictures while still in shooting mode, making it possible to view the results of earlier attempts while setting up the next shot. Quick review is available in **[CAMERA]**, **P**, **S**, **A**, **M**, **SCENE**, and **[PLAY]** modes. Press the **[QUICK]** button once to view pictures in the top left corner of the monitor, with the view through the lens visible in the background. Press the **[QUICK]** button again to view pictures full screen. To return to shooting mode, press the **[QUICK]** button a third time or press the shutter-release button halfway.

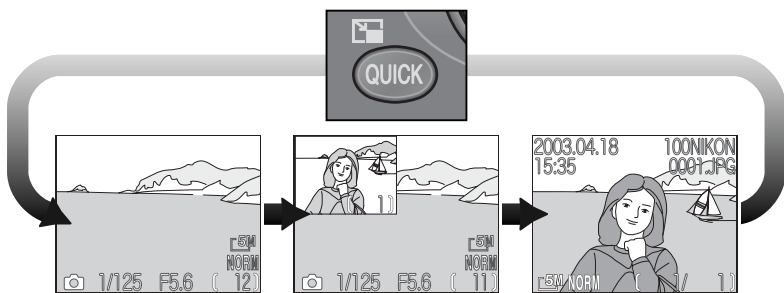

Shooting Mode

Quick Review

Pictures are displayed in top left corner of the monitor. Use to check results of earlier attempts while setting up the next shot.

Full-Screen Review

View pictures full screen or in "contact sheets" of four or nine thumbnail images. View photo information, zoom in on pictures, or delete shots one at a time.

Full-Screen Playback

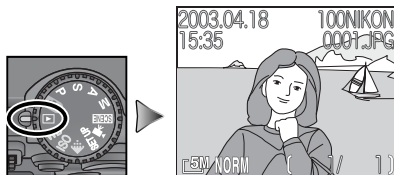

When you rotate the mode dial to , the most recent picture will be displayed full-screen in the monitor.



Viewing Additional Pictures

Press the multi selector down or right to view pictures in the order recorded, up or left to view pictures in reverse order. Keep the multi selector pressed to scroll rapidly to the desired frame number.

Keep or Delete

In  (movie) mode or when image quality is set to HI, or when **Ultra HS** is selected for **Continuous** in **P**, **S**, **A**, or **M** mode, pictures will be displayed briefly after each shot. To delete the picture before it is recorded to the memory card, press the AF () button. A confirmation dialog will be displayed. Press the multi selector up or down to highlight an option, then press the center of the multi selector to select.

- Select **No** to exit without deleting the picture.
- Select **Yes** to delete the picture.

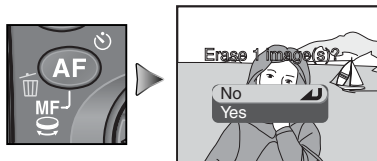
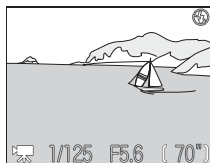

Deleting Pictures

To delete the picture currently displayed in full-screen review or full-screen playback, press the AF () button. A confirmation dialog will be displayed; delete the picture as described above under "Keep or Delete."

Photo Information

More on Playback

In full-screen review and full-screen playback, information about each picture is superimposed on the image. There are six pages of photo information for each picture. Rotate the command dial to cycle through photo information as follows: Page 1 ↔ Page 2 ↔ Page 3 ↔ Page 4 ↔ Page 5 ↔ Page 6 ↔ Page 1.

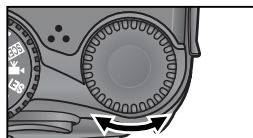

Page 1 (File Information)

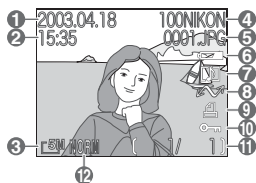

- 1 Date of recording
- 2 Time of recording
- 3 Image size
- 4 Folder
- 5 File number and type
- 6 Battery level indicator
- 7 Voice memo icon
- 8 Transfer icon
- 9 Print-order icon
- 10 Protect icon
- 11 Current frame number/total number of frames visible in current folder
- 12 Image quality

Page 2 (Shooting Information)

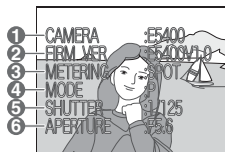

- 1 Camera type
- 2 Firmware version
- 3 Metering method
- 4 Exposure mode
- 5 Shutter speed
- 6 Aperture

Page 3 (Shooting Information, continued)



- 1 Exposure compensation
- 2 Focal length
- 3 Focus mode
- 4 Flash status
- 5 Image adjustment
- 6 Sensitivity (ISO equivalency)

Page 4 (Shooting Information, continued)



- 1 White balance
- 2 Color saturation
- 3 Sharpening
- 4 Digital zoom
- 5 Converter lens status
- 6 File size

Page 5 (Exposure Information)

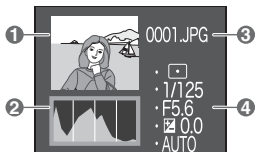

- 1 Thumbnail preview (flashing border marks image highlights—i.e., brightest areas of image)
- 2 Histogram (shows distribution of tones in image; horizontal axis corresponds to pixel brightness, with dark tones to left and bright tones to right, while vertical axis shows number of pixels of each brightness in image)
- 3 File number and type
- 4 Exposure information (metering, shutter speed, aperture, exposure compensation, sensitivity)

Page 6 (Focus Confirmation)

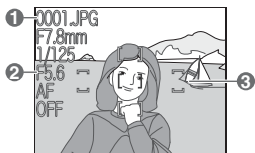













- 1 File number and type
- 2 Focus information (focal length, shutter speed, aperture, focus mode, noise reduction)
- 3 Focus confirmation (areas of picture that are in focus are sharply outlined; active focus area is shown in red)

▶ Viewing Multiple Pictures: Thumbnail Playback



More on Playback

Pressing the   button in full-screen review or full-screen playback displays the pictures on the memory card in “contact sheets” of four thumbnail images. The following operations can be performed while thumbnails are displayed:







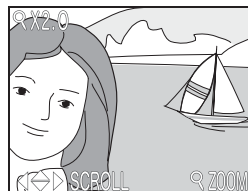

To	Use	Description
Highlight pictures		Press multi selector up, down, left, or right to highlight pictures.
Page through pictures		Rotate the command dial to scroll through thumbnails a page at a time.
Change number of pictures displayed	  	With four thumbnails displayed, press   button once to view nine thumbnails. Press  (Q) to “zoom in” from nine thumbnails to four thumbnail-view or, when four thumbnails are displayed, to view highlighted picture full screen.
Delete highlighted picture	 	Confirmation dialog will be displayed. Press multi selector up or down to highlight option, press center to select. <div data-bbox="329 837 578 1026" style="border: 1px solid black; padding: 5px; margin-top: 10px;"> <p>SELECTED IMAGES</p> <p>Erase 1 Image(s)?</p> <p>No </p> <p>Yes</p> </div> <ul style="list-style-type: none"> • Select No to exit without deleting picture • Select Yes to delete picture
View highlighted picture full screen		Press center of multi selector to view highlighted picture full screen.

Taking a Closer Look: Playback Zoom



Use the  () button to zoom in on still images displayed in full-screen review and full-screen playback.



To	Press	Description
Zoom in	 ()	Zoom increases each time button is pressed, to a maximum of about 6x. While image is zoomed in,  icon and zoom ratio are displayed in top left corner of monitor.
View other areas of picture		Use multi selector to scroll to areas of picture not visible in monitor. To use multi selector to view other pictures, cancel zoom.
Zoom out	 	Zoom decreases each time button is pressed. To cancel zoom, zoom picture out until entire picture is displayed.
Cancel zoom		Cancel zoom and return to full-screen display.

Playback Zoom

Playback zoom is not available with movies, still pictures created with the **Ultra HS** option in the **Continuous** menu, or with small copies created using the small picture option.





















Before a HI-quality image can be displayed at higher zoom ratios, additional data must be read from the memory card. If the  () button is pressed immediately after the picture is displayed full screen, a message will be displayed in the monitor. Wait a few seconds and try again.

▶ Adding Audio Commentary: Voice Memo



More on Playback







Brief voice memos can be added to still pictures displayed in full-screen playback. Voice memos can not be added to movies. Memos are stored on the memory card as WAV-format sound files. During playback, the presence of a memo is indicated by a  icon.



To	Press	Description
Record memo		Memo of up to 20s can be recorded while  button is pressed. Recording ends after about 20s or when  button is released.
Play memo		If  icon appears in file information display during playback, memo can be played back by pressing  button. Playback ends when entire recording has been played back or  button is pressed a second time.
Pause/resume playback		Press center of multi selector to pause playback. Press again to resume.
Raise volume	 	Volume indicator displayed in monitor when zoom buttons are pressed. Three levels are available: high () , low () , and mute (). Default setting is high.
Lower volume	 	
Delete memo	 	Pressing AF () button while memo is being played back displays confirmation dialog. Press multi selector up or down to highlight option, press center to select. <div data-bbox="357 958 606 1155" style="border: 1px solid black; padding: 5px; margin-top: 10px;"> <p>SELECTED IMAGES</p> <p>Erase 1 image(s)?</p> <p>No </p> <p></p> <p>Yes</p> </div> <ul style="list-style-type: none"> • Select No to exit without deleting picture or voice memo • Select  to delete voice memo without deleting picture • Select Yes to delete picture and voice memo

Creating Small Copies: Small Picture

In full-screen playback, you can press the **QUICK** () button to create a small copy of the current picture. Depending on the option selected for **Small pic** in the playback menu ( 115), copies will be 640×480, 320×240, or 160×120 pixels in size. Copies have an image quality of BASIC, making them ideal for distribution by e-mail or for use in web pages.

<p>1</p>  <p>Confirmation dialog displayed.</p>	<p>SMALL PIC</p> <p>Create small picture file ?</p> <p>No </p> <p>Yes </p>	<p>2</p>  <p>Highlight Yes (to exit without creating small copy, highlight No and press center of multi selector).</p>	<p>SMALL PIC</p> <p>Create small picture file ?</p> <p>No </p> <p>Yes </p>
<p>3</p>  <p>Create copy and return to full-screen playback.</p>	<p>To view the copy, use the multi selector to scroll to the last picture in memory. When viewed on the camera, copies are surrounded by a gray border.</p>		

Copies are stored as files with names of the form “SSCNnnnn.JPG,” where “nnnn” is a four-digit number assigned by adding one to the largest file number in the current folder. Copies are independent of the originals: deleting the copy has no effect on the original, deleting the original no effect on the copy. Copies are created with the same transfer marking and date and time of recording as the original; print and protect attributes are not set.

Copies can not be viewed using playback zoom.

Restrictions on Small Picture

Copies can only be created when sufficient space is available on the memory card. Copies can not be created in quick review or full-frame review. Copies can not be created from movies, from other small pictures, or from pictures taken at **Ultra HS**, an image quality of **HI**, or an image size of  **2592 × 1728**. You may not be able to create copies from pictures taken with another model of camera.

Viewing Small Picture Files on Other Camera Models

Small copies may not display or transfer correctly on other camera models.

Viewing Pictures on TV

The EG-E5000 audio/video cable included with the camera can be used to connect the camera to a television or video-cassette recorder (VCR).

Choosing a Video Mode

The **Video mode** item in the setup menu offers a choice of NTSC and PAL (144). Be sure that the mode selected matches the standard used in the video device. In PAL video mode, video output will be suspended and the camera monitor will turn on when you shoot movies or take pictures at **Ultra HS**.

More on Playback

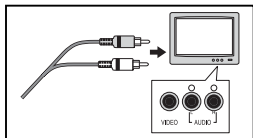
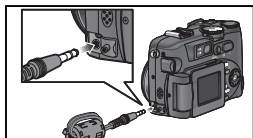

- 1 Turn the camera off
- 2 Connect the audio/video cable
Insert the black plug into the camera's interface connector, the yellow plug into the video-in jack on the television or VCR. Connect the white plug to the audio-in jack.
- 3 Tune the television to the video channel
If in doubt, consult the documentation for your television or VCR.
- 4 Select  mode
- 5 Turn the camera on
The camera monitor will remain off and the television will display the image normally shown in the monitor. If the camera is connected to a VCR, images can be recorded to video tape.

Viewing Pictures on a Computer

Using the UC-E1 USB cable and Nikon View software provided with your camera, you can view pictures on a computer. Before pictures can be transferred (copied) to a computer, Nikon View must be installed. For more information on installing Nikon View and transferring pictures to your computer, see the *Nikon View Reference Manual* (on CD-ROM) and the reverse side of the *Quick Start Guide*.

Before Connecting the Camera

Before transferring pictures to a computer, set the USB option in the camera setup menu to match the computer's operating system (134). The camera supports two options: **Mass storage** (the default option) and **PTP** (Picture Transfer Protocol).

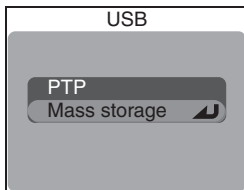

Operating system	USB option
Windows XP Home Edition Windows XP Professional Mac OS X (10.1.2–10.2)	Choose Mass storage or PTP .
Windows 2000 Professional Windows Millennium Edition (Me) Windows 98 Second Edition (SE) Mac OS 9 (9.0–9.2)	Choose Mass storage .

▶ Connecting the USB Cable

More on Playback

Turn the computer on and wait for it to start up. After confirming that the camera is off, connect the UC-E1 USB cable as shown below. Connect the camera directly to the computer; do not connect the cable via a USB hub or keyboard.

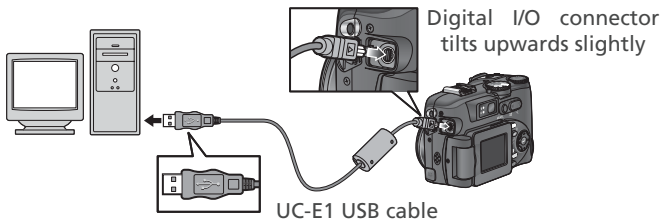

Turn the camera on and transfer pictures as described on the reverse side of the *Quick Start Guide*.

✎ **Windows 2000 Professional, Windows Millennium Edition (Me), Windows 98 Second Edition (SE), Mac OS 9 (9.0–9.2)**

Do **NOT** select **PTP** when connecting the camera to a computer running one of the above operating systems. If the camera has been connected to a computer running one of the above operating systems with **PTP** selected in the **USB** menu, disconnect the camera as described below. Be sure to select **Mass storage** before reconnecting the camera.

Windows 2000 Professional

The computer will display the welcome dialog for the Found New Hardware Wizard. Click **Cancel** to close the dialog, and then disconnect the camera.

Windows Millennium Edition (Me)

After displaying a message stating that the hardware information database is being updated, the computer will start the Add New Hardware Wizard. Click **Cancel** to exit the wizard, and then disconnect the camera.

Windows 98 Second Edition (SE)

The Add New Hardware Wizard will be displayed. Click **Cancel** to exit the wizard, and then disconnect the camera.

Mac OS 9 (9.0–9.2)

A dialog will be displayed stating that the computer is unable to use the driver needed for the "Nikon Digital Camera E5400_PTP" USB device. Click **Cancel** to close the dialog, and then disconnect the camera.

Disconnecting the Camera

If **PTP** is selected in the **USB** menu (83), the camera can be turned off and the USB cable disconnected once transfer is complete. If the **USB** option in the camera setup menu is still at its default setting of **Mass storage**, the camera must first be removed from the system as described below.

Windows XP Home Edition/Windows XP Professional

Click the "Safely Remove Hardware" icon (84) in the taskbar and select **Safely remove USB Mass Storage Device** from the menu that appears.



Windows 2000 Professional

Click the "Unplug or Eject Hardware" icon (85) in the taskbar and select **Stop USB Mass Storage Device** from the menu that appears.



Windows Millennium Edition (Me)

Click the "Unplug or Eject Hardware" icon (86) in the taskbar and select **Stop USB Disk** from the menu that appears.



Windows 98 Second Edition (SE)

In My Computer, click with the right mouse button on the removable disk corresponding to the camera and select **Eject** from the menu that appears.

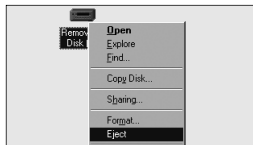

Mac OS X

Drag the "NO_NAME" camera volume into the Trash.

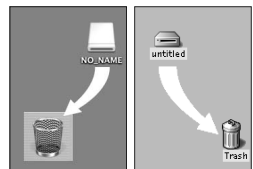

Mac OS X

Mac OS 9

Drag the "untitled" camera volume into the Trash.

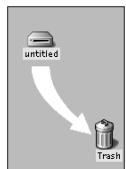



Mac OS 9

Printing Pictures

To print the pictures from the camera memory card:

- take the card to a digital print service center
- insert the card into a personal photo printer equipped with a CompactFlash™ card slot
- transfer the pictures using Nikon View and print them from a computer (see the *Nikon View Reference Manual*, on CD-ROM)

To print the time and date of recording on pictures:

- take pictures using the **Date imprint** option in the setup menu, which imprints the date or date and time of recording directly on pictures as they are taken ( 145)
- if the photo printer or print service supports Digital Print Order Format (DPOF), use the **Date** option in the **Print set > Print selection** menu ( 127)
- transfer the pictures using Nikon View and print them using the Nikon View date imprint option (see the *Nikon View Reference Manual*, on CD-ROM)

"Print Set" and Digital Print Order Format (DPOF)

The **Print set** option in the playback menu is used to create a digital "print order" listing the pictures to be printed, the number of prints, and the information to be included on each print. This print order is stored on the camera memory card in Digital Print Order Format (DPOF). Once a print order has been created, the memory card can be inserted in a DPOF-compatible device and the pictures printed directly from the card. Before using this option, check that the printer or print service supports DPOF. Note that:

- If the **Print set** option has not been used to create a print order, all the pictures on the memory card will be printed
- The print order is not copied to the computer when pictures are transferred using Nikon View

"Date Imprint" Versus the Print Set "Date" Option

Date imprint	Print selection > Date
Must be set before picture is taken	Set after picture is taken
Date permanently imprinted on picture	Date stored separately
Date appears whenever picture is printed	Date only appears when picture is printed on DPOF-compatible printer

Movies



Your Nikon digital camera can record three different types of movie. This chapter describes how to record and view movies.

Recording Movies 📽 88

Viewing Movies 📽 92

Recording Movies



1 Select  mode
Rotate the mode dial to , turn the camera on, and open the monitor. In place of the number of exposures remaining, the monitor will show the maximum length of the movie that can be recorded at current settings.

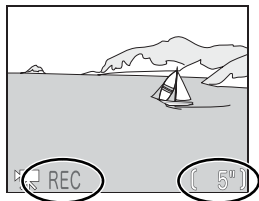

2 Record movie
Press the shutter-release button all the way down to start recording. While recording is in progress, a **REC** indicator is displayed. Recording ends when the shutter-release button is pressed a second time, when the memory card is full, or when the movie has reached its maximum length.

Using the Flash

The flash turns off (🚫) automatically when **TV movie (640)** or **Small movie (320)** is selected.

Zoom

When **TV movie (640)** or **Small movie (320)** is selected, optical zoom can only be adjusted before recording begins. Before and during recording, digital zoom can be adjusted between 1.2× and 2.0×. Pressing the zoom button during recording triggers digital zoom, even if **Off** has been selected for **Zoom options > Digital tele** (📷 105).

	Before recording	During recording
Optical zoom	Can be adjusted normally.	Fixed at position selected before recording.
Digital zoom	1.2×–2.0× from maximum optical zoom position.	1.2×–2.0× from current optical zoom position (from maximum optical position if digital zoom was in effect when recording began).

The Monitor

If the monitor is swivelled to point in the same direction as the lens when recording a **TV movie (640)** or **Small movie (320)**, the display in the monitor will be inverted.

Focus Mode

If **Single AF** (the default option) is selected for **Focus options > Auto-focus mode** (📷 70), focus will lock when the shutter-release button is pressed to start recording.

The type of movie recorded can be selected from the following options:

Option	Description
TV movie (640)	Movies are recorded at a rate of 15 frames per second, with sound recorded via built-in microphone. Vertical interlacing is used to achieve a size of 640×480 pixels, suitable for television playback. Maximum length for TV movies is 70s.
Small movie (320) (default option)	Movies are recorded at a rate of 15 frames per second, with sound recorded via built-in microphone. Each frame has a size of 320×240 pixels. Maximum length for small movies is 180s.
Time-lapse movie	Camera takes still pictures at specified intervals and joins these frames together to create silent movie with frame rate of 30 frames per second. Resulting movie may be up to 60s long. Use to create time-lapse movies of slow processes that can be filmed without moving the camera: a flower opening, a butterfly emerging from its cocoon, clouds moving across the sky, etc.

To choose the type of movie that will be recorded:

1



Display MOVIE menu.

2

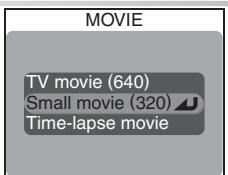

Highlight option (press **MENU** button to exit without changing settings).

3

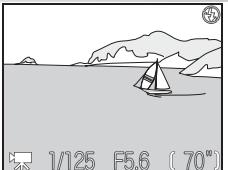

Return to shooting mode (if **Time-lapse movie** is selected, menu of time-lapse movie options will be displayed; see following page). Record movie as described on previous page.

Movie Files

Movies are recorded as Quick Time movie files with the extension “.MOV” and can be played back on a computer after transfer.

Recording a Time-Lapse Movie

1

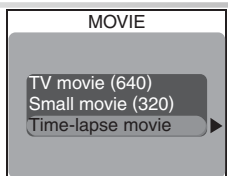

In movie menu, highlight **Time-lapse movie**.

2

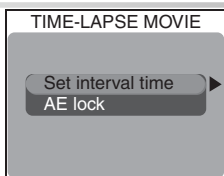

Display time-lapse movie options.

3

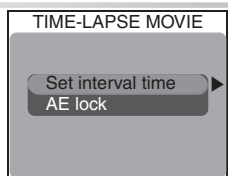

Highlight **Set interval time**.

4

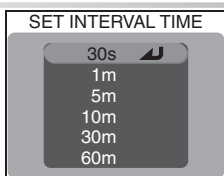

Display options.

5

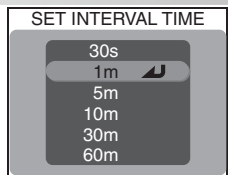

Choose interval between frames from **30s** (thirty seconds), **1m** (one minute), **5m** (five minutes), **10m** (ten minutes), **30m** (thirty minutes), and **60m** (sixty minutes).

6

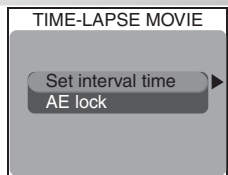

Make selection.

Restrictions on Time-Lapse Movie

Time-lapse movie is not available at HI image quality or an image size of **3:2** 2592 × 1728.

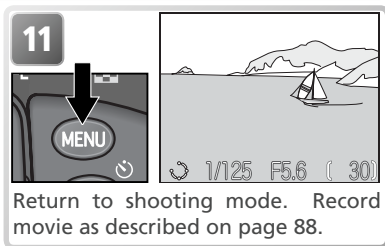
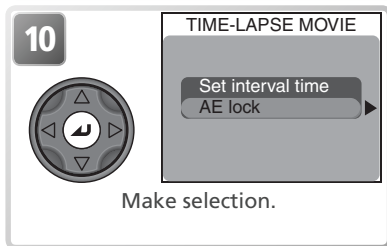
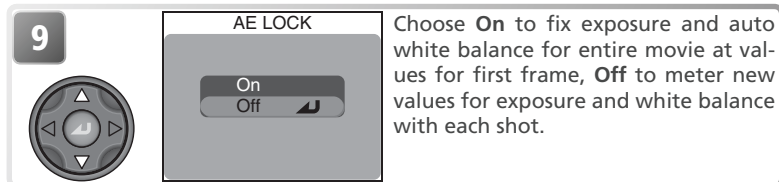
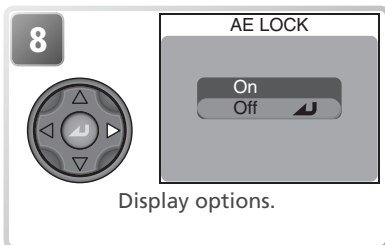
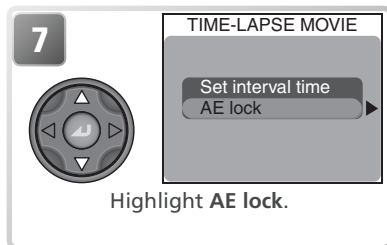

Take Test Shots

We recommend taking a test shot and viewing the results in the monitor before recording movies at a setting of **Time-lapse movie**.



During Recording

To save power, the monitor turns off between frames; the green (AF) lamp blinks to show that recording is in progress. The monitor turns on automatically about ten seconds before the camera takes the next shot. Time-lapse photography will end automatically if the camera is unable to finish recording a frame in the selected interval (this may occur if a microdrive or other memory card with a slow write time is used).







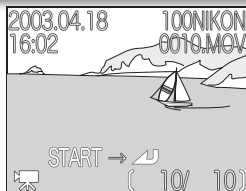

Use a Reliable Power Source

We recommend using the optional EH-53 AC adapter or EH-21 AC adapter/battery charger when recording time-lapse photos at intervals of ten minutes or more.

Viewing Movies

To play a movie back, rotate the mode dial to  and display the movie in full-screen playback (movie files are indicated by a  icon). Press the center of the multi selector to begin playback. If the movie was recorded with the **TV movie (640)** or **Small movie (320)** option, sound recorded with the movie will be played back over the camera's built-in speaker.



To	Press	Description
Start/pause/resume playback		Press center of multi selector to start playback. While playback is in progress, pressing center of multi selector pauses playback. Press again to resume. When movie ends, first frame of movie will be displayed.
Rewind movie one frame		When movie is paused, pressing multi selector up or left rewinds movie one frame.
Advance movie one frame		When movie is paused, pressing multi selector down or right advances movie one frame. When end of movie is reached, pressing multi selector down or right ends playback and displays first frame of movie.
Raise volume		Volume indicator displayed in monitor when zoom buttons are pressed. Three levels are available: high () , low () , and mute (). Default setting is high.
Lower volume		

Viewing Time-Lapse Movies

When a movie is recorded using the **Time-lapse movie** option, two files are created: the original and a second, smaller copy for playback on the camera. The original is recorded at the image quality and size settings in effect when shooting begins, while the copy has an image quality of NORMAL and a frame size of 320×240 pixels. On the memory card, the copy will have a file number one greater than the original; if the original had the file name "MSCN0001.MOV," the copy would be named "DSCN0002.MOV." Originals can only be played back on a computer; when viewed on the camera, they are displayed as still pictures showing the movie's first frame.

Menu Guide

This chapter describes the options available in the following menus:

The Shooting Menu 94

Adjust camera settings when shooting in **P**, **S**, **A**, and **M** modes.

The Playback Menu 115

Delete selected pictures or folders, organize pictures into folders, select pictures for transfer to a computer or for printing on a DPOF-compatible device, protect pictures from accidental deletion, and hide pictures during playback.

The Setup Menu 134

Adjust basic camera settings and perform such tasks as formatting memory cards and choosing a folder to store your pictures.

The Shooting Menu

When the mode dial is set to **P**, **S**, **A**, or **M**, the settings listed below can be adjusted from the shooting menu (the shooting menu is not available in **▶** and **SCENE** modes). To display the shooting menu:

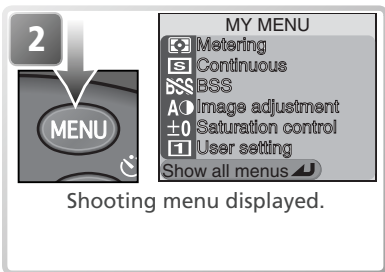
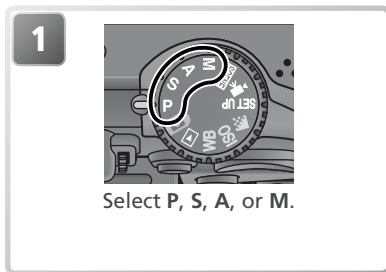

Pressing the **MENU** button displays a one-page custom menu containing six items selected from a total of twenty options available in the full shooting menu. You can choose what items appear in the custom menu using the **My menu** option (▶ 113). To display the full shooting menu, which consists of three pages of options:

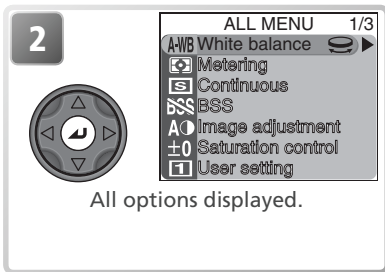
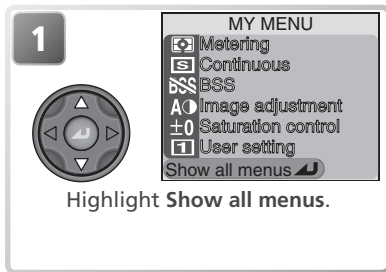

Using the Menus

For more information on menu operations, see “Before You Begin: Using the Menus” (▶ 10).

The full shooting menu contains the following options:

ALL MENU 1/3	
White balance	
Metering	
Continuous	
BSS	
Image adjustment	
Saturation control	
User setting	

ALL MENU 1/3		
White balance	60–62	
Metering	68	
Continuous	63–64	
BSS	97	
Image adjustment	66	
Saturation control	67	
User setting	98–99	

ALL MENU 2/3	
Image quality/size	
Sensitivity	
Image sharpening	
Lens	
Exposure options	
Focus options	
Zoom options	

ALL MENU 2/3		
Image quality/size	54–57	
Sensitivity	58–59	
Image sharpening	65	
Lens	101–102	
Exposure options	103–104	
Focus options	69	
Zoom options	105	

ALL MENU 3/3	
Speedlight opt.	
Auto bracketing	
Noise reduction	
Reset	
My menu	
CF card format	

ALL MENU 3/3		
Speedlight opt.	106–108	
Auto bracketing	109–110	
Noise reduction	111	
Reset	112	
My menu	113–114	
CF card format	114	

White Balance

There are eight options for white balance; see “More on Photography: White Balance” for details (📖 60).

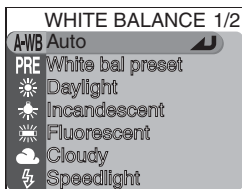

Metering

Four metering methods can be selected; see “More on Photography: Metering” for details (📖 68).

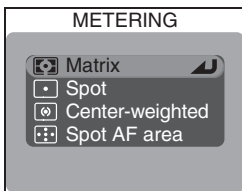

Continuous

Six options are available for taking pictures in a sequence; see “More on Photography: Continuous” for details (📖 63).

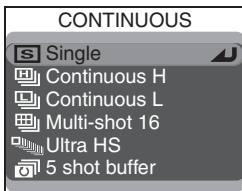

Restrictions on BSS (📖 97)

BSS can not be used with the self-timer (📖 35), **Continuous** options other than **Single** (📖 63), exposure or white-balance bracketing (📖 109), or noise reduction (📖 111).

BSS

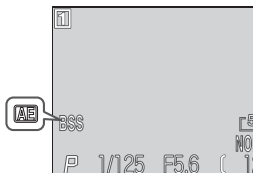

At settings other than **Off**, the current BSS setting is indicated by an icon in the monitor.

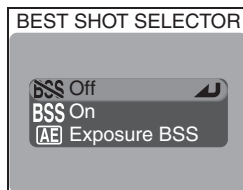

Best Shot Selector (BSS)

The options in the “best-shot selector” (BSS) menu are recommended for situations in which inadvertent camera movement can produce blurred pictures, or when parts of the image are prone to under- or over-exposure.



Option	Description
 Off	BSS off.
 On	Camera takes shots while shutter-release button is pressed, to a maximum of ten. These images are then compared and sharpest picture (picture with highest level of detail) saved to memory card. Flash turns off automatically and focus, exposure, and auto white balance for all photos are determined by the first picture in each series. Recommended for situations in which inadvertent camera movement can produce blurred pictures, for example when: <ul style="list-style-type: none"> • the camera is zoomed in • macro close-up is in effect • lighting is poor and the flash can not be used This setting may not produce desired results with moving subjects or if composition is changed during shooting.
 Exposure BSS	Selecting this option displays sub-menu shown at right. Choose from: <ul style="list-style-type: none"> • Highlight BSS: picture with smallest area of overexposure is selected. • Shadow BSS: picture with smallest area of underexposure is selected. • Histogram BSS: of pictures with least under- and over-exposure, camera chooses picture with overall exposure closest to optimum. Camera takes five shots each time shutter-release button is pressed. These images are then compared and picture that best meets selected criterion saved to memory card. Flash turns off automatically and focus and auto white balance for all photos are determined by the first picture in each series. Recommended for subjects containing areas of high contrast, when it is difficult to set exposure correctly.

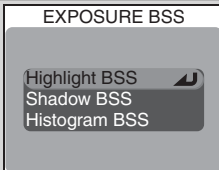
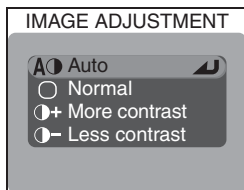

Image Adjustment

This option is used to adjust contrast. See “More on Photography: Sharpening, Contrast, and Color” (📖 66).



Saturation Control

Use this option to adjust the vividness of colors and take pictures in black-and-white. See “More on Photography: Sharpening, Contrast, and Color” (📖 67).

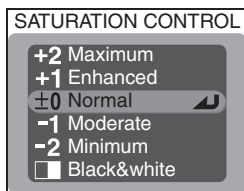

User Setting

Camera settings can be stored in two separate “banks,” Bank 1 and Bank 2. By default, changes to camera settings are stored in Bank 1. To store another combination of frequently-used settings, select Bank 2 and set the camera appropriately. To switch from one combination of settings to the other, select the desired bank from the **User setting** menu.

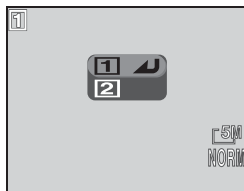

User settings banks store the following settings:

Shooting menu settings			
White balance†	Image quality	Bulb/time	Flash exposure comp.
Metering	Image size	AF area mode	Speedlight ctrl
Continuous	Sensitivity (ISO)	Auto-focus mode	Repeating flash
BSS	Image sharpening	Focus confirmation	Auto bracketing
Image adjustment	Lens‡	Digital tele	Noise reduction
Saturation control	AE lock	Fixed aperture	

Other settings		
Flash mode	Focus mode	Exposure compensation

† Any changes to fine tuning and preset white balance apply to both banks, regardless of the bank currently selected.

‡ If **Slide copy adptr** is selected, **Lens** will be set to **Slide copy adptr > Positive** when the settings bank is recalled.

To select a user settings bank:

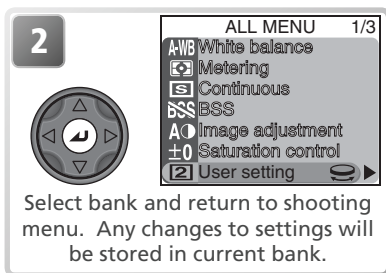
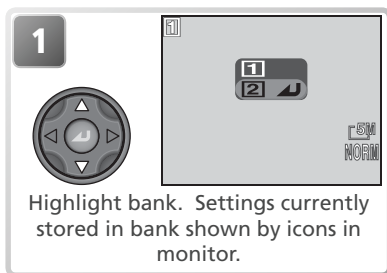

User Setting

In **P**, **S**, **A**, and **M** modes, the number of the current user settings bank appears in the top left corner of the monitor.



Image Quality and Size

Selecting **Image quality/size** displays the menu shown at right, where image quality and size can be selected from separate sub-menus. For more information, see “More on Photography: Image Quality and Size” (📖 54).



Sensitivity

Choose this option to set sensitivity (ISO equivalency). For more information, see “More on Photography: Sensitivity” (📖 58).

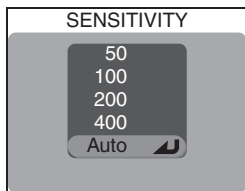
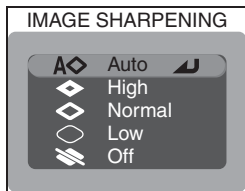

Image Sharpening







This option controls the amount of sharpening performed when pictures are saved to the memory card. See “More on Photography: Sharpening, Contrast, and Color” (📖 65).

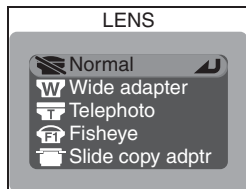

Lens

The lens menu is used to adjust camera settings for optimal results with the optional converter lenses and adapters listed below. Note that these accessories can only be used with a lens adapter ring (📷 148). For complete information on use and handling, see the documentation provided with each converter lens.



Option	Description
 Normal	No modifications are made to settings. Use when no converter lens is attached (be sure to remove lens adapter ring).
 Wide adapter (for WC-E80)	<ul style="list-style-type: none"> •Camera zooms out to widest angle. Zoom can be adjusted manually (📷 26). •Maximum aperture in mode P is f/4. To prevent blurring at edges of frame in modes S, A, and M, adjust settings to produce apertures no wider than f/4.
 Telephoto (for TC-E15ED)	Optical zoom fixed at maximum optical zoom position. Digital zoom can be used (📷 26).
 Fisheye (for FC-E9)	<ul style="list-style-type: none"> •Zoom fixed at widest angle (📷 26). •Focus fixed at infinity (📷 34). •Metering fixed at center-weighted (📷 68). •Corners of frame blacked out to create circular frame.
 Slide copy adptr (for ES-E28)	<p>Selecting this item displays options shown at right. Choose Positive when photographing color film, Inverse color when examining film negatives in monitor.</p>  <ul style="list-style-type: none"> •Zoom fixed close to maximum zoom position; digital zoom set to 1.1 ×. Digital zoom can be adjusted manually (📷 26). •Focus mode can be chosen from macro close-up and macro close-up with self-timer (📷 34). •Exposure compensation (📷 36) set to +0.7 EV (Positive) or +1.3 EV (Inverse color). •Image adjustment set to Less contrast (📷 66).

The Shooting Menu

Using a Flash

The built-in Speedlight turns off automatically at settings other than **Normal**. Optional Speedlights mounted on the accessory shoe ( 148) can be used at settings of **Wide adapter** and **Telephoto**.

Use Autofocus

When shooting at settings other than **Normal**, use autofocus ( 34). Results in manual focus mode will not accurately reflect the focus distance selected.

Slide Copy Adapter: Inverse Color

The **Inverse Color** option requires a bright light source. If lighting is insufficient, the image in the monitor will be too bright. Should you notice excessive “noise” in the form of randomly-spaced, bright pixels, set image sharpening to **Off** or **Low** ( 65).

Inverse Color is intended for use only when examining film negatives in the monitor, and the quality of the image produced will vary widely with the type and make of film used. We recommend using a film scanner such as the Nikon COOLSCAN to obtain high-quality digital images from negative film.

Lens Adapter Rings

Remove optional lens adapter rings ( 148) when not in use. The corners of the frame will be eclipsed in any pictures taken while a lens adapter ring is mounted on the camera without a converter lens attached.

Lens

At settings other than **Normal**, the current lens setting is indicated by an icon in the monitor.

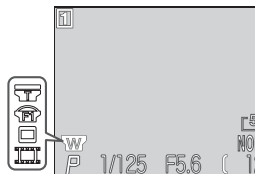

Exposure Options

The exposure options menu contains two options for controlling exposure.

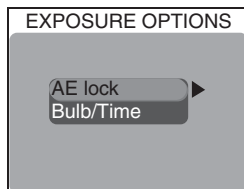

AE Lock

When taking a series of pictures that will later be joined to form a single image (for example, when taking shots for a panorama or 360° virtual-reality image), you can use autoexposure (AE) lock to obtain the same exposure and auto white balance settings for all pictures in the series.

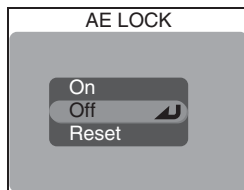

Option	Description
On	First picture taken after On is selected sets exposure (shutter speed, aperture, and sensitivity) and auto white balance for all subsequent pictures. Flash turns off while AE lock is in effect.
Off	Restores normal exposure and white balance.
Reset	Clears existing exposure settings. First picture taken after this option is selected sets exposure (shutter speed, aperture, and sensitivity) and auto white balance for all subsequent pictures.

AE Lock

While AE lock is in effect, an **AE-L** (autoexposure lock) icon appears in the monitor. After you select **On** or **Reset**, this icon turns yellow to indicate that exposure will be locked with the next shot. The icon will turn white once you have taken a picture to set exposure.

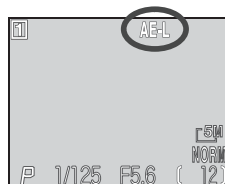

The Shooting Menu

Bulb/Time

In mode **M** (manual exposure mode), shutter speed can be set to BULB or TIME for long exposures of up to ten minutes (📷 53). This menu controls how long exposures are made.

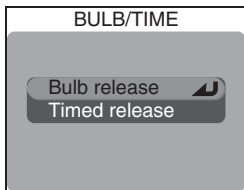

Option	Description
Bulb release	Shutter will remain open as long as shutter-release button is held down, to a maximum of ten minutes.
Timed release	Selecting this option displays menu of exposure times. Choose from 30s (thirty seconds), 1m (one minute), 3m (three minutes), 5m (five minutes), or 10m (ten minutes). Shutter will open when shutter-release button is pressed and will remain open until specified exposure time has elapsed or the shutter-release button is pressed again.

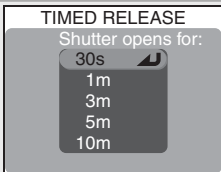

📷 Long Exposures

Longer exposure times increase the amount of noise visible in the picture; we recommend that noise reduction (📷 111) be turned on for long exposures.

Focus Options

The focus options menu contains three options controlling focus settings. For more information, see “More on Photography: More on Focus” (69).

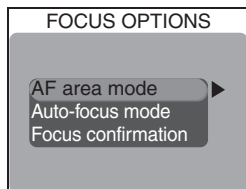

Zoom Options

The **Zoom options** menu contains options for digital and optical zoom.

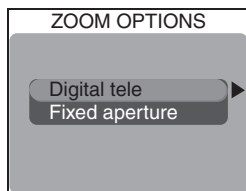

Digital Tele

Select **On** to enable digital zoom when the monitor is on. If **Off** is selected, pressing the **T** button at the maximum optical zoom position has no effect (digital zoom can still be used while recording movies).



Fixed Aperture

This option controls whether aperture varies with zoom position.

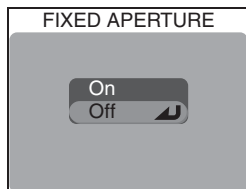

Option	Description
On	In A and M modes, aperture is kept as close as possible to selected f/-number. To prevent selected f/-number from exceeding exposure range at new zoom position, choose aperture of around f/5 to f/8.
Off	Aperture changes as you zoom in and out.

Controlling the Flash: Speedlight Options

In **P**, **S**, **A**, and **M** modes, the built-in Speedlight and optional external flash units are controlled according to the options selected for **Speedlight opt.**

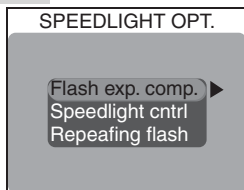

Controlling Flash Output: *Flash Exp. Comp.*

Use this option to adjust flash output by -2.0EV to $+2.0\text{EV}$ in increments of $\frac{1}{3}\text{EV}$.

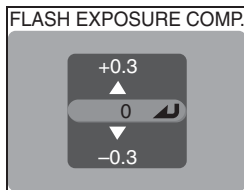

Options for Optional Speedlights: *Speedlight Cntrl*

This option is used to control the built-in and optional Speedlights when using optional flash accessories mounted on the camera's accessory shoe.

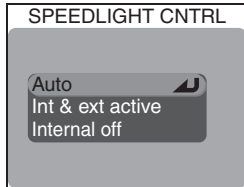

Option	Description
Auto	Optional Speedlight fires. If no optional Speedlight is mounted on the camera, built-in Speedlight will fire instead.
Int & ext active	Both optional and built-in Speedlights fire (built-in Speedlight will not fire if not required for correct exposure).
Internal off	Built-in Speedlight turns off.

Strobe Photography: Repeating Flash

When **On** is selected for **Repeating flash**, the flash will fire at regular intervals during each exposure, allowing you to capture a moving object in several different positions in a single frame. When using this option, rotate the mode dial to **M** (manual exposure mode) and choose a shutter speed of BULB or TIME (53). At other shutter speeds, the flash will fire only once. If an optional Speedlight is used, only the optional Speedlight will fire; the built-in Speedlight will turn off.

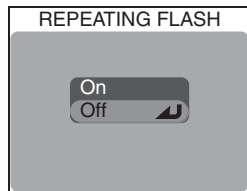

Option	Description
On	Selecting On displays menu shown at right. Interval can be set to values between 1Hz (flash fires once a second) and 10Hz (flash fires ten times a second) in increments of 1Hz. <div data-bbox="689 589 952 789" style="border: 1px solid black; padding: 5px; margin-top: 10px;"> REPEATING FLASH 2Hz ▲ 1Hz ◀ </div>
Off	Normal flash operation restored.

SB-27 and SB-23 Speedlights

Set **Speedlight cntrl** to **Auto** or **Internal off** when using an SB-27 or SB-23 Speedlight.

The HN-CP10 Lens Hood

Remove the HN-CP10 lens hood (available separately; 148) when using the flash.

Optional Speedlights

The following SB-series Nikon Speedlights (all available separately) can be mounted directly on the camera accessory shoe without a sync cable: 80DX, 50DX, 28DX, 30, 28, 27, 26, 25, 24, 23, and 22s. The accessory shoe is equipped with a safety lock for Speedlights with a locking pin (SB-series 28DX, 30, 28, 27, 26, 25, and 22s).

Using Optional Speedlights







Refer to the Speedlight manual for detailed instructions. Before using an optional Speedlight, set the zoom head to an angle wider than 28mm. At smaller angles, the flash may not light the entire subject. We recommend that you take a test shot and view it in the monitor; if the results are not satisfactory, try zooming the camera in or adjusting the illuminating angle. When a WC-E80 is used with the camera zoomed all the way out, the combined focal length is 22 mm (35-mm format equivalent). Use a wide panel for an illuminating angle wider than 22 mm.

Set the Speedlight flash mode to TTL before shooting. At this setting, the optional Speedlight will be controlled by the camera in response to flash mode (📷 32) and **Speedlight opt.** (📷 106) settings. When the flash fires, the amount of light produced by the optional Speedlight is measured by the camera's photocell, and the length of the flash adjusted to ensure optimal exposure. D-TTL flash control (available with the SB-80DX, SB-50DX, and SB-28DX) is not supported.

When set to STBY (standby), the optional Speedlight will turn on when the camera is turned on, but will not turn off when the camera is turned off. The COOLPIX5400 does not support power zoom, AF-assist illumination, or red-eye reduction by means of the red-eye reduction lamp on the optional Speedlight.

Flash Mode Indicators for Optional Speedlights

When **Internal off** or **Auto** is selected for **Speedlight cntrl** and an optional Speedlight is mounted on the camera, flash mode is indicated in the monitor as shown at right. Note that the camera will not detect the optional Speedlight if the flash-ready lamp is off. Be sure the flash ready lamp on the optional Speedlight is lit before taking a picture.

Flash mode	Icon
Auto	
Flash Cancel (off)	
Auto with red-eye reduction	
Anytime Flash (fill flash)	
Slow sync	
Rear-curtain sync	

Auto Bracketing

In some situations, you may find it difficult to select appropriate exposure-compensation and white-balance settings, and yet not have time to check the results and adjust settings after each shot. Auto bracketing can be used to vary these settings automatically over a series of pictures, “bracketing” a selected exposure-compensation or white-balance setting.

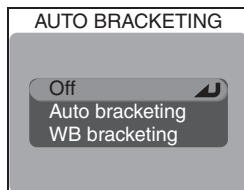

Option	Description
Off	Restores normal exposure and white balance.
Auto bracketing	Camera varies exposure with each shot, bracketing current exposure compensation value (autoexposure bracketing; 36).
WB bracketing	Camera takes three shots each time shutter-release button is fully pressed, bracketing current white balance setting to produce one picture with normal white balance, one picture with reddish cast, and one picture with bluish cast. Recording time roughly triples. Use when unsure of appropriate value for white balance.

Restrictions on Auto Bracketing

Autoexposure bracketing can not be used in combination with a shutter speed of **BULB** or **TIME** (104), **BSS** (97), exposure **BSS** (97), **AE lock** (103), noise reduction (111), or with **Continuous** settings of **Multi-shot 16**, **Ultra HS**, or **5 shot buffer** (63).

White balance bracketing can not be used in combination with **BSS** (97), exposure **BSS** (97), **AE lock** (103), noise reduction (111), an image quality of **HI** (54), **Black&white** (67), or with **Continuous** settings other than **Single** (63).



Auto Bracketing

When autoexposure bracketing is in effect, a **BKT** icon is displayed in the monitor with the selected exposure increment.

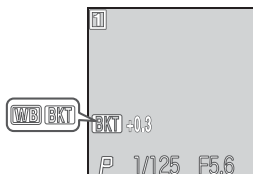
When white balance bracketing is in effect, **WB** and **BKT** icons appear in the monitor.



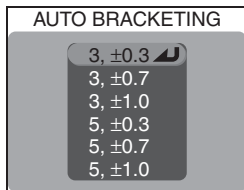

Autoexposure Bracketing

When **Auto bracketing** is selected, exposure varies with each shot; the number of shots and amount of exposure compensation performed are selected from the sub-menu shown at right. Values are added to the exposure compensation value selected with the  button ( 36). Bracketing is performed by varying shutter speed (**A** and **M** modes), aperture (**S** mode), or shutter speed and aperture (**P** mode).





Option	No. of shots	Exposure increment	Bracketing order
3, ±0.3	3	± $\frac{1}{3}$ EV	0, +0.3, -0.3
3, ±0.7	3	± $\frac{2}{3}$ EV	0, +0.7, -0.7
3, ±1.0	3	±1 EV	0, +1.0, -1.0
5, ±0.3	5	± $\frac{1}{3}$ EV	0, +0.7, +0.3, -0.3, -0.7
5, ±0.7	5	± $\frac{2}{3}$ EV	0, +1.3, +0.7, -0.7, -1.3
5, ±1.0	5	±1 EV	0, +2.0, +1.0, -1.0, -2.0

After taking a series of shots using bracketing, you can view the results in quick review ( 74) or playback ( 75) and select the pictures with the desired exposure, discarding the remaining shots if so desired.

Continuous Shooting (Autoexposure Bracketing)

At settings of **Continuous H** and **Continuous L** ( 63), shooting will pause after each bracketing cycle is complete.

Auto Flash and Auto ISO (Autoexposure Bracketing)

In auto flash mode ( 32), the flash setting for the first shot in each bracketing cycle applies to the remaining pictures. If the flash fires on the first shot, it will fire for the remaining shots; if the flash does not fire on the first shot, it will not fire for the remaining shots. If sensitivity (ISO equivalency) is set to **Auto** ( 58), the sensitivity value for the first shot in each bracketing cycle will also apply to the remaining pictures.



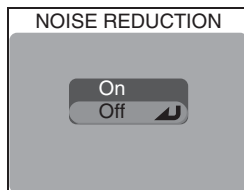

Noise Reduction

At shutter speeds slower than about $\frac{1}{4}$ s, “noise” in the form of randomly-spaced, brightly-colored pixels may appear in pictures, particularly in shadows. Noise reduction can be used to reduce noise at slow shutter speeds.



Option	Description
On	Noise reduction takes effect at shutter speeds of about $\frac{1}{4}$ s or slower. Time required to save pictures to memory card more than doubles.
Off	Noise reduction off; camera functions normally.

Restrictions on Noise Reduction

Noise reduction can not be used in combination with BSS ( 97), exposure BSS ( 97), bracketing ( 109), **Continuous** settings other than **Single** ( 63), or with a **Lens** setting of **Slide copy adptr** ( 101).

Sensitivity (ISO Equivalency)

Noise reduction will reduce the noise that occurs at higher sensitivities ( 58), but only in pictures taken at shutter speeds of $\frac{1}{4}$ s or slower.

Noise Reduction

When noise reduction is on, an **NR** icon appears in the monitor.



Reset

Reset is used to restore settings for the current User Setting bank to their default values.

Option	Description
No	Exit menu, leaving settings unchanged.
Reset	Restore settings to default values.

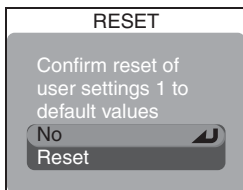

Choosing **Reset** restores the following options for the current User Setting bank to their default values. Settings in the other bank are unaffected.

Basic settings	Default
Flash mode	Auto
Focus mode	Autofocus
Exposure compensation	±0

Mode dial settings	Default
White balance	Auto*
Image quality/size	
Image quality	Normal
Image size	2592 × 1944
Sensitivity	Auto

Menu options	Default
Metering	Matrix
Continuous	Single
BSS	Off
Image adjustment	Auto
Saturation control	Normal
Image sharpening	Auto

Menu options	Default
Lens	Normal
Exposure options	
AE lock	Off
Bulb/time	Bulb release
Focus options	
AF area mode	Auto
Auto-focus mode	Single AF
Focus confirmation	Manual focus
Zoom options	
Digital tele	On
Fixed aperture	Off
Speedlight options	
Flash exposure comp.	0
Speedlight cntrl	Auto
Repeating flash	Off
Auto bracketing	Off
Noise reduction	Off

* Fine-tuning reset to 0.

My Menu

This option determines which of the twenty items in the full shooting menu appear in the six-item custom menu displayed when you press the **MENU** button in **P**, **S**, **A**, or **M** mode. At default settings, the custom menu contains the metering, continuous, BSS, image adjustment, saturation control, and User Setting items. If desired, other frequently-used items can be placed in the custom menu for quick access (note that the same item can not appear more than once in the custom menu).

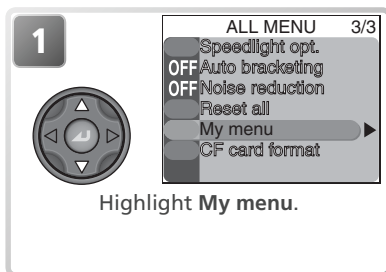
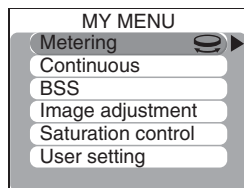

Highlight **My menu**.

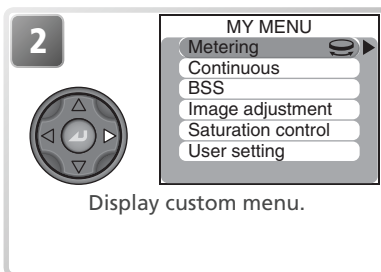

Display custom menu.

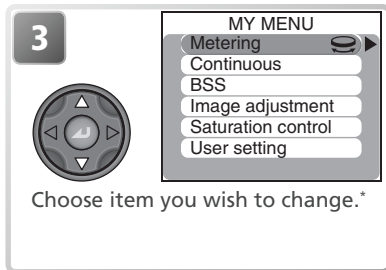

Choose item you wish to change.*

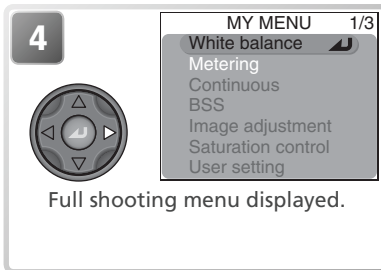

Full shooting menu displayed.

* Selection can also be made by highlighting item in Step 3 and rotating command dial. Press center of multi selector to save changes to menu and return to shooting mode.

The Shooting Menu

5



Select item to be added to custom menu.

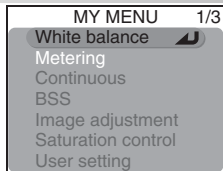

6



Replace item selected in custom menu with item selected in full shooting menu.

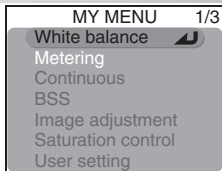

7

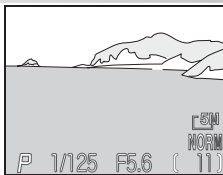
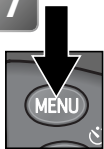

Return to shooting mode.

CF Card Format

CF card format formats memory cards for use in the camera. *Note that formatting memory cards permanently deletes all data they contain, including protected pictures and any other data that may be on the card.* Before formatting, be sure to transfer any valued pictures to a computer (83–85).

CF CARD FORMAT

WARNING!
All images will be deleted !

No
Format

Option	Description
No	Exit without formatting memory card.
Format	Format memory card. Message shown at right displayed while formatting is in progress. <i>Do not turn the camera off, remove the batteries or memory card, or unplug the AC adapter (available separately) while this message is displayed.</i>

FORMATTING

The Playback Menu

The playback menu contains the following options:

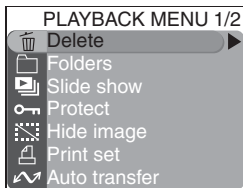

PLAYBACK MENU 1/2	
Delete	116–117
Folders	118–122
Slide show	123–124
Protect	125
Hide image	126
Print set	127–128
Auto transfer	129–130

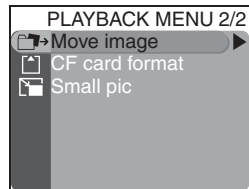

PLAYBACK MENU 2/2	
Move image	131–132
CF card format	114
Small pic	133

To display the playback menu:

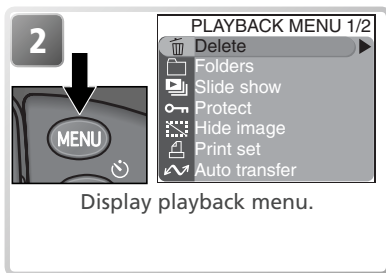

Using the Menus

For more information on menu operations, see “Before You Begin: Using the Menus” (10).

Delete

The delete menu contains the following options:

Option	Description
Selected images	Delete selected pictures.
Erase all images	Delete all pictures.

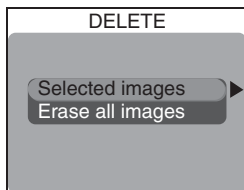

Deleting Selected Pictures

- Highlight **Selected images**.
- Pictures on memory card displayed as thumbnail images.
- Highlight picture.
- Select highlighted picture. Selected pictures marked by icon.
- Repeat steps 3 and 4 to select additional pictures. To deselect picture, highlight and press multi selector up or down. To exit without deleting pictures, press button.

6

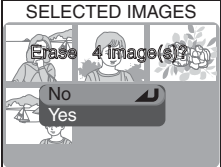

Confirmation dialog displayed. Press multi selector up or down to highlight option, press center to select.

- Select **No** to exit without deleting selected pictures
- Select **Yes** to delete selected pictures

Deleting All Pictures



To delete all unprotected pictures on the memory card:

1

Highlight **Erase all images**.

2

Confirmation dialog displayed. Press multi selector up or down to highlight option, press center to select.

- Select **No** to exit without deleting pictures
- Select **Yes** to delete all pictures that are neither hidden nor protected

Before Deletion

Once deleted, pictures can not be recovered. If desired, transfer pictures to a computer before deletion (📖 83–85).

Protected Pictures

Pictures marked with a  icon are protected and can not be deleted (📖 125).

Hidden Pictures

Pictures hidden with the **Hide image** option (📖 126) are not displayed in the **Delete > Selected images** menu and can not be deleted.

Folders

By default, pictures are stored in a folder with the name NIKON. To make it easier to locate pictures during playback, additional folders can be created to organize pictures by theme. The playback **Folders** menu is used create and manage folders, and to select the folder from which pictures will be played back.

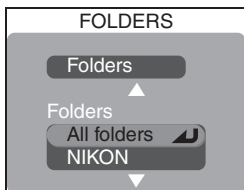

Folder Options

The **Folders** item in the playback **Folders** menu contains the following options:



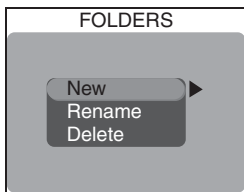





Option	Description
New	Create new folders.
Rename	Rename existing folders.
Delete	Delete folders and all items they contain.

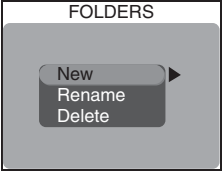

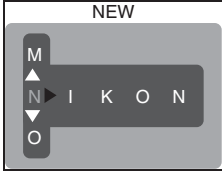
Folder Options

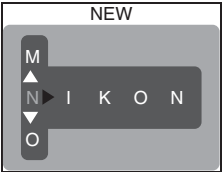
The **Folders** menu can also be accessed using the **Folders** item in the setup menu (135).

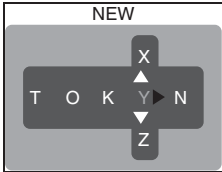
Creating New Folders

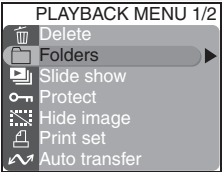
- 1**   Highlight **New**.
- 2**   Display default folder name (NIKON).
- 3**   Highlight letter.
- 4**   Edit letter. Folder names can include upper case letters ("A"–"Z"), numbers, and spaces.
- 5** Repeat steps 3 and 4 to create new five-letter folder name. Press  button to exit without creating folder.
- 6**   Highlight last letter and press center of multi selector to create new folder. Until another folder is selected in **Folders** menu, all new images will be stored in new folder.





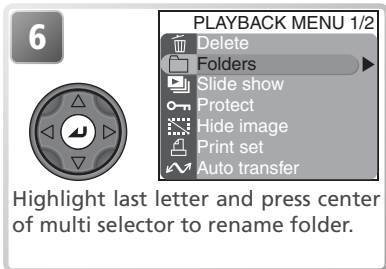
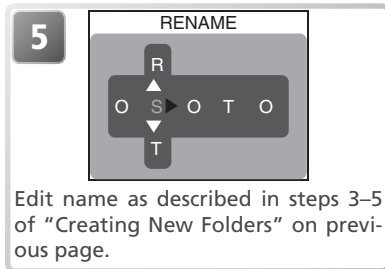
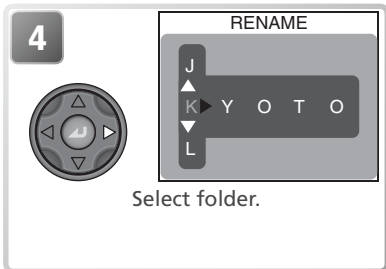
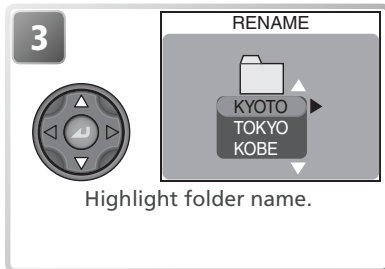
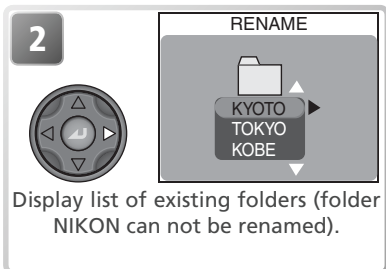
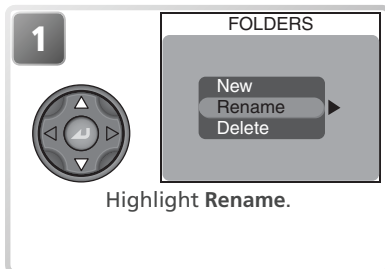

The Playback Menu

Renaming Existing Folders

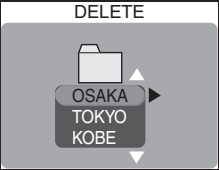

To exit the RENAME dialog without renaming the folder, press the button.

Deleting Folders

<p>1</p>  <p>Highlight Delete.</p>	<p>FOLDERS</p> 	<p>2</p>  <p>Display list of existing folders (folder NIKON can not be deleted).</p>	<p>DELETE</p> 
<p>3</p> 	<p>DELETE</p> 	<p>Highlight folder name.</p>	
<p>4</p> 	<p>DELETE</p> <p>Delete : OSAKA</p> <p>Confirm folder deletion?</p> 	<p>Confirmation dialog displayed. Press multi selector up or down to highlight option, press center to select.</p> <ul style="list-style-type: none"> • Select No or press MENU button to exit without deleting folder • Select Yes to delete selected folder 	

Hidden and Protected Pictures

If the selected folder contains hidden or protected pictures, the folder will not be deleted. Note, however, that any pictures it contains that are neither hidden nor protected *will* be deleted.



The Playback Menu

Choosing a Folder for Playback

The **Folders** item in the playback menu can be used to select all folders for playback, or to view pictures in a selected folder.





1

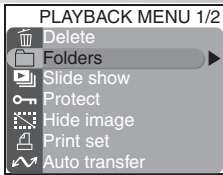

Highlight folder. To view pictures in all folders, select **All folders**.

2



Select folder and return to playback menu.

3



Press **MENU** button to display most recent picture in selected folder in full-frame playback.

Panorama Assist/Ultra HS

Each series of pictures taken at a setting of **Panorama assist** (44) or **Ultra HS** (63) is stored in a separate folder. Folders created at a setting of **Panorama assist** are listed in the **Folders** menu under names beginning with "P_" followed by a three-digit number; folders taken at **Ultra HS** are listed under names beginning with "N_" followed by a three-digit number. To view only the pictures in a selected series, choose the appropriate folder from the **Folders** menu. To delete all pictures in a selected series, select the appropriate folder in the **Folders > Folders > Delete** menu.

Slide Show

When **Start** is selected in the slide show menu, all pictures in the current folder that have not been hidden using **Hide image** (🔒 126) will be played back one after the other in the order recorded, with a pause between each image. Movies will be played back as still images showing the movie's first frame.

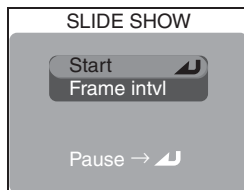

Option	Description
Start	Start slide show.
Frame intvl	Choose how long each picture will be displayed.

Viewing a Slide Show

1

Highlight **Start**.

2

Start slide show.

3



When slide show ends, PAUSE menu is displayed (see following page). Press multi selector left to return to playback menu, or press **MENU** button to return to full-frame playback.

🔌 Auto Off

The camera will enter standby mode if no operations are performed for thirty minutes during a slide show.

The Playback Menu

The following operations can be performed during a slide show:

To	Press	Description
Pause slide show		Dialog shown at right will be displayed. To restart slide show, highlight Restart and press center of multi selector. To end slide show and return to playback menu, press multi selector to left. To end slide show and return to full-frame playback, press MENU button.
Go forward or back one frame		Press multi selector up or left to go back one frame, down or right to skip ahead to next frame.
End slide show		End slide show and return to full-frame playback.

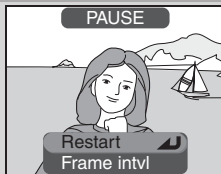

Changing the Display Interval

The slide show menu on the previous page and the pause dialog shown above contain a **Frame intvl** option for choosing how long each picture will be displayed. To change the display interval, highlight **Frame intvl** and press the center of the multi selector. The menu of interval settings shown at right will be displayed; highlight the desired setting and press the center of the multi selector.

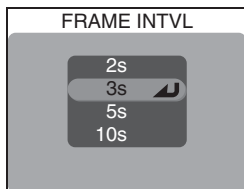

Frame Interval

Owing to differences in file size and the speed at which pictures can be read from the memory card, the actual interval may differ from the value selected.

Protect

Protected files can not be deleted by pressing the AF (🗑️) button or using the delete options in the playback and folder menus. Note, however, that protected pictures **will** be deleted when the memory card is formatted.

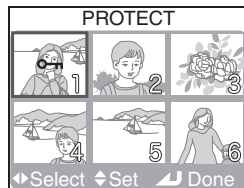

1

Highlight picture.

2

Select highlighted picture. Selected pictures marked by icon.

3 Repeat steps 1 and 2 to select additional pictures. To deselect picture, highlight and press multi selector up or down. To exit without changing protected status of pictures, press button.

4

Complete operation and return to playback menu.

Hide Image

When creating a slide show or showing pictures to an audience, the **Hide image** option can be used to hide selected pictures. Hidden pictures are visible only in the **Hide image** menu. They can not be deleted by pressing the AF (🗑️) button or using the delete options in the playback and folder menus. Note, however, that hidden pictures **will** be deleted when the memory card is formatted.



1

Highlight picture.

2

Select highlighted picture. Selected pictures marked by icon.

3 Repeat steps 1 and 2 to select additional pictures. To deselect picture, highlight and press multi selector up or down. To exit without changing hidden status of pictures, press button.

4

Complete operation and return to playback menu.

"ALL IMAGES ARE HIDDEN"

If all pictures in the current folder are hidden, the message "ALL IMAGES ARE HIDDEN" will be displayed in quick review and full-frame playback. No pictures can be viewed until another folder has been selected or **Hide image** is used to reveal some of the pictures in the current folder.

Print Set

Print set is used to select pictures for printing on devices that support Digital Print Order Format (DPOF), to choose the number of copies to be printed, and to specify the information to be included with each print. For information on printing pictures selected using this option, see “More on Playback: Printing Pictures” (86).

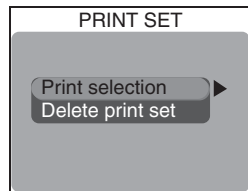

Option	Description
Print selection	Create or modify print order as described below.
Delete print set	Cancel print order. Print marking will be removed from all pictures in print order, but pictures will not be deleted.

To create a print order or modify the existing print order:

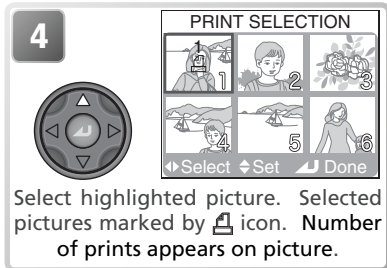
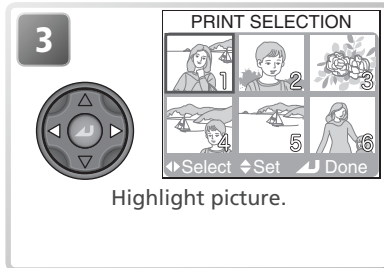
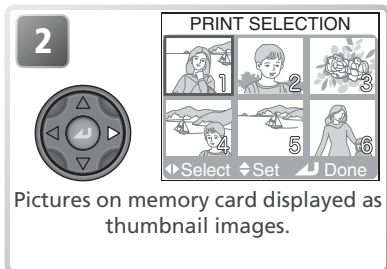
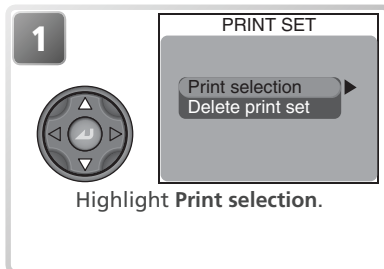

The Playback Menu

5

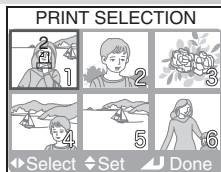

Use multi selector to specify number of prints (up to 9). To deselect picture, press multi selector down when number of prints is 1. Repeat steps 3–5 to select additional pictures. To exit without altering print order, press **MENU** button.

6

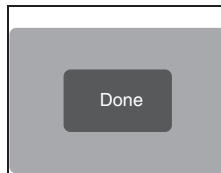
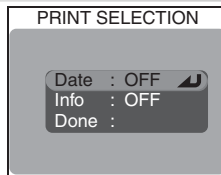

Press center of multi selector to complete print order and display menu of print options.

- To print date of recording on all pictures in print order, highlight **Date** and press center of multi selector. **ON** will appear next to item.
 - To print shutter speed and aperture on all pictures in print order, highlight **Info** and press center of multi selector. **ON** will appear next to item.
 - To turn selected item off, highlight and press center of multi selector.
- To complete print order and return to playback, highlight **Done** and press center of multi selector. To exit without altering print order, press **MENU** button.

"Date"

If **Date** is selected in the PRINT SELECTION menu, the date of recording will appear on any pictures printed using devices that support the DPOF date function. Note that the information printed on the image will not be correct unless the camera clock was set correctly when the picture was taken.



Print Set

If you display the PRINT SELECTION menu after creating a print order, the **Date** and **Info** options will be reset.

Auto Transfer

When the camera is connected to a computer running Nikon View, pictures selected with **Auto transfer** can be transferred (copied) to the computer (83).

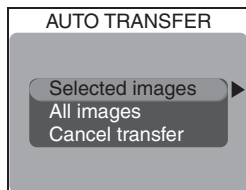

Option	Description
Selected images	Select pictures for transfer.
All images	Mark all pictures for transfer.
Cancel transfer	Remove transfer marking from all pictures.

Marking Selected Pictures for Transfer

1

Highlight **Selected images**.

2

Pictures on memory card displayed as thumbnail images.

3

Highlight picture.

4

Select highlighted picture. Selected pictures marked by icon.

The Playback Menu

- 5** Repeat steps 3 and 4 to select additional pictures. To deselect picture, highlight and press multi selector up or down. To exit without changing transfer status of pictures, press **MENU** button.

6



Complete operation and return to playback menu.

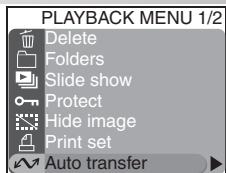

Marking All Pictures for Transfer

1



AUTO TRANSFER

Selected images
All images
Cancel transfer

Highlight **All images**.

2



ALL IMAGES

All images will be transferred. OK?
No
Yes

Confirmation dialog displayed. Press multi selector up or down to highlight option, press center to select.

- Select **No** to exit without selecting pictures for transfer
- Select **Yes** to select all pictures for transfer

Restrictions on Auto Transfer

No more than 999 pictures can be transferred using **Auto transfer**. To transfer more than 999 pictures, select the images in Nikon View, or select and transfer pictures in batches of 999 or less.

The COOLPIX5400 can not be used to transfer pictures selected for transfer with another model of Nikon digital camera. Use the COOLPIX5400 to reselect the pictures.

Move Image

To move pictures to another folder on the current memory card:

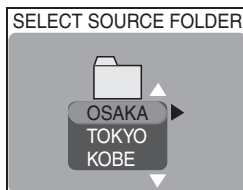

1

Select folder containing pictures to be moved to another folder.

2

Pictures on memory card displayed as thumbnail images.

3

Highlight picture.

4

Select highlighted picture. Selected pictures marked by icon.

5 Repeat steps 3 and 4 to select additional pictures. To deselect picture, highlight and press multi selector up or down.

6

Display list of possible destination folders.

The Playback Menu

7



SELECT DEST. FOLDER



Highlight destination folder.

8



MOVE IMAGE(S)?

Confirm image move to another folder?

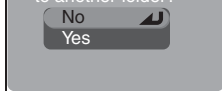

Confirmation dialog displayed. Press multi selector up or down to highlight option, press center to select.

- Select **No** to exit without moving pictures
- Select **Yes** to move pictures to selected folder

info.txt

Moving pictures deletes the associated entries from the info.txt file (143).

File Names

When a picture is moved, it will be assigned a new file number generated by adding one to the highest file number in the destination folder. The identifier (DSCN or SSCN) and extension (.TIF, .JPG, .MOV) will not change.

Destination Folders

The following can not be selected as destination folders:

- Folders created at **Ultra HS** (folder names begin with "N_")
- Folders created at a setting of **Panorama assist** (folder names begin with "P_")
- Folders that already contain the maximum of two hundred pictures
- Folders that already contain a picture numbered 9999

Pictures of the following types can not be moved to another folder:

- Pictures created at a setting of **Ultra HS** and stored in folders with names that begin with "N_"
- Pictures created at a setting of **Panorama assist** and stored in folders with names that begin with "P_"

CF Card Format

CF card format formats memory cards for use in the camera. See “Shooting Menu Options: CF Card Format” (📷 114).

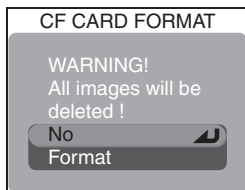

Small Pic

Small pic controls the size of copies created with the small picture option (📷 81). Choose from sizes of 640 × 480, 320 × 240, and 160 × 120.

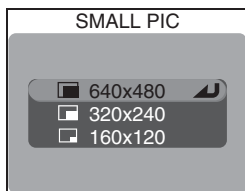

The Setup Menu

The setup menu contains the following options:

SET-UP 1/3	
En Language	▶
🕒 Date	
📁 Folders	
📺 Monitor options	
ON Seq. numbers	
ON Shutter sound	
1m Auto off	

SET-UP 2/3	
📁 CF card format	▶
FUNCD Controls	
ON Shot confirmation	
ON info.txt	
🔌 USB	
NTSC Video mode	
C Reset all	

SET-UP 3/3	
📅 Date imprint	▶
Ver Firmware version	

SET-UP 1/3	
Language	20
Date	20–21
Folders	135
Monitor options	136–137
Seq. numbers	138
Shutter sound	139
Auto off	140

SET-UP 2/3	
CF card format	114
Controls	141–142
Shot confirmation	143
info.txt	143
USB	144
Video mode	144
Reset all	144

SET-UP 3/3	
Date imprint	145
Firmware version	145

To display the setup menu, rotate the mode dial to **SET UP**.

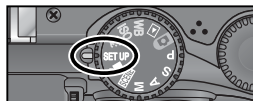

Using the Menus

For more information on menu operations, see “Before You Begin: Using the Menus” (📖 10).

Language

Use the **Language** option to choose a language for camera menus and messages. See “First Steps: Basic Setup” (📖 20).

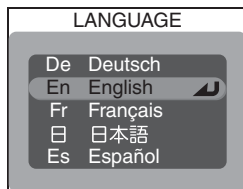

Date

Date is used to set the camera clock to the current date and time. See “First Steps: Basic Setup” (📖 20).

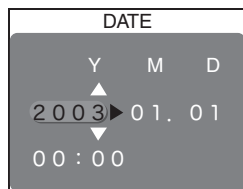

Folders

In addition to creating, renaming, and deleting folders (📖 118), the folders option in the setup menu can be used to select the folder in which subsequent pictures will be stored. Press the multi selector up or down to highlight a folder and then press the center of the multi selector to select the highlighted folder and return to the setup menu. Until a new folder is selected, all new pictures will be stored in the chosen folder.



📌 Panorama Assist/Ultra HS

Folders created with the **Panorama assist** (📖 44) and **Ultra HS** (📖 63) options can not be used to store additional pictures.

📌 Folder Options

For more information on the **Folders** item in the **Folders** menu, see “Playback Menu Options: Folders” (📖 118).

Monitor Options

The options in this menu control the quality of the preview displayed in the monitor, the conditions under which the monitor will turn on automatically, and monitor brightness and hue.

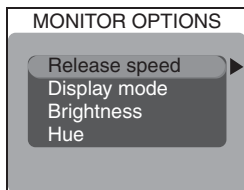

Release Speed

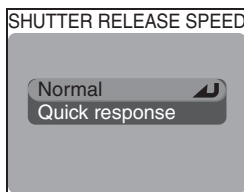

The image from the camera's image sensor (CCD) must be processed before it can be displayed in the camera monitor, creating a slight display lag. In **P**, **S**, **A**, and **M** modes, this option can be used to minimize the delay between the shutter-release button being pressed and the picture being taken, at the cost of a slight drop in the quality of the preview image displayed in the monitor.



Option	Description
Normal	Priority given to quality of preview image displayed in monitor.
Quick response	Reduces lag between shutter-release button being pressed and shutter being released in P , S , A , and M modes.* Horizontal lines may appear when view through lens is previewed in monitor; this has no effect on pictures taken at this setting. This setting does not take effect in VIDEO , SCENE , and MOVIE movie modes.

* If the shutter-release button is pressed all the way down to take a picture during "keep or delete" (75), the focus, exposure, and auto white-balance settings used in the previous shot will apply to the new picture. To ensure a quick response, the built-in Speedlight will not fire if a picture is taken during "keep or delete"; optional Speedlights will not fire if **Continuous** is set to **Single**.

Display Mode

This option specifies the conditions under which the monitor will turn on automatically at startup, and whether pictures are displayed in the monitor after shooting (“keep or delete”;  75). It takes effect only in **P**, **S**, **A**, and **M** modes; in all other modes, the monitor functions normally. Regardless of the setting chosen, the monitor can still be turned on or off using the  button.

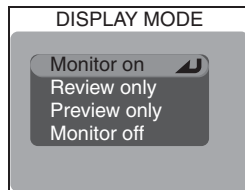

Option	Monitor on at startup	“Keep or delete”
Monitor on	Yes	Yes
Review only	No	Yes
Preview only	Yes	No
Monitor off	No	No

Brightness

This option controls monitor brightness. Press the multi selector up or down to increase or decrease brightness. The results of any changes are immediately visible in the center of the display. Press the center of the multi selector to put the change into effect and return to the setup menu.

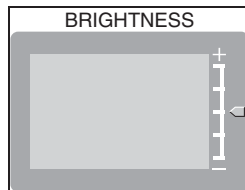

Hue

This option controls monitor hue (tone). Pressing the multi selector up gives the display a bluish cast, pressing it down a reddish cast. The results are visible in the center of the display. Press the center of the multi selector to put the change into effect and return to the setup menu.

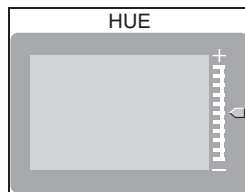

“Brightness” and “Hue”

Changes to these settings have no effect on the image displayed in the television screen when the camera is connected to a TV or VCR ( 82). The **Brightness** and **Hue** options can not be selected while the EG-E5000 video cable is connected.

Seq. Numbers

Pictures are assigned file names that include a four-digit file number assigned automatically by the camera (e.g., "DSCN0001.JPG") and stored in folders with names that contain a three digit folder number (e.g., "100NIKON"). Each folder holds up to 200 pictures. This option controls how file numbers are assigned.



Option	Description
On	When new picture is taken, file number is generated by adding one to last file number used. If picture is taken when current folder is full, new folder will be created by adding one to current folder number and file numbering will continue from last number used. File numbering will also continue from last number used if memory card is formatted or new memory card inserted in camera. If picture is taken when current folder contains picture numbered 9999, new folder will be created by adding one to current folder number and file numbering will begin again from 0001.
Off	As above, except that file numbering is reset to 0001 when new folder is created, memory card is formatted, or new memory card is inserted in camera.
Reset	Clears last file number from memory. If memory card is formatted or empty memory card inserted before Reset is selected, file numbering will begin from 0001. If memory card already contains pictures, next file number will be generated by adding one to highest file number in current folder.

File Numbering

If file numbering reaches 9999 when the current folder contains a picture numbered 999, no more pictures can be taken until the memory card is formatted or a new card inserted, even if enough memory is available on the card to store more pictures.

Image File Names

Pictures are identified by file names with three parts: a four letter identifier, a four-digit file number, and a three-letter extension (e.g., "DSCN0001.JPG"). Identifiers are assigned according to how the picture was created, extensions according to file type:

Picture type	Identifier	File type	Extension
Original	DSCN	Hi-quality still pictures	.TIF
Small copy 81)	SSCN	Other still pictures	.JPG
		Movies	.MOV

Shutter Sound

Shutter sound controls the “beep” made by the camera speaker.



Option	Description
On	<p><i>Camera beeps once to confirm that:</i></p> <ul style="list-style-type: none"> • camera has completed preparations for shooting • shutter-release button has been fully pressed to release shutter (no beep will sound when Release speed is set to Quick response) • manual focus has been activated or converter lens option selected in Lens menu • images have been deleted or memory card formatted • changes have been made to image status with Protect, Hide image, Print set, or Auto transfer items in playback menu • Shutter sound has been set to on <p><i>Camera beeps twice to warn that:</i></p> <ul style="list-style-type: none"> • camera is not in focus when shutter-release button has been pressed half-way (only when monitor off) <p><i>Camera beeps four times to warn that:</i></p> <ul style="list-style-type: none"> • memory card is full or not inserted when shutter-release button is pressed
Off	Confirmation and warning beeps disabled. Voice memos and sound recorded with movies can still be played back.

Auto Off

When operated on battery power, the camera will enter standby mode if no operations are performed for the length of time selected in the AUTO OFF menu. Choose from thirty seconds (**30s**), one minute (**1m**, the default setting), five minutes (**5m**), or thirty minutes (**30m**). Regardless of the option chosen in the AUTO OFF menu, the monitor will remain on for three minutes when menus are displayed. The camera will not enter standby mode while connected to a computer.

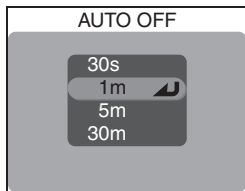

CF Card Format

CF card format formats memory cards for use in the camera. See "Shooting Menu Options: CF Card Format" (👁 114).

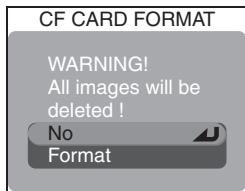

🔪 2CR5 (DL245) Batteries

When powered by a six-volt 2CR5 (DL245) lithium battery, the camera may become hot if left on for an extended period. We recommend that you set **Auto off** to five minutes or less when using this type of battery.

🔌 Standby Mode

In standby mode, all camera functions are deactivated and the camera itself is effectively off, consuming almost no power. The camera can be reactivated by pressing the  button or by pressing the shutter-release button halfway.

🔌 Using an AC Adapter

When powered by an optional EH-53 AC adapter or EH-21 AC adapter/battery charger, the camera will remain on for thirty minutes if no operations are performed, regardless of the setting chosen in the **Auto off** menu. If the camera is connected to a video device, video output will continue indefinitely after the monitor has turned off.

Controls

This menu contains the following options:

Option	Description
FUNC	Specify function performed by FUNC. button.
AE-L, AF-L	Specify function performed by AE/AF-L button.

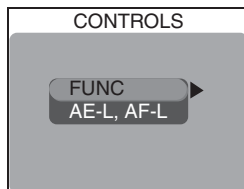

FUNC

This option controls the function assigned to the FUNC. button, making it possible to select the User Setting number or adjust white balance, image quality, sensitivity (ISO equivalency), or metering without accessing the camera menus.

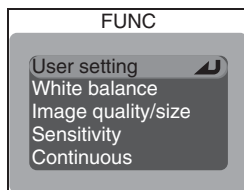

Option	Description
User setting	When camera is in mode P , S , A , or M , User Setting bank changes each time FUNC. button is pressed.
White balance	White balance can be set by pressing FUNC. button and rotating command dial when camera is in mode P , S , A , or M . White balance can not be fine-tuned using FUNC. button. When preset white balance is selected, camera will measure new value for preset white balance if FUNC. button is kept pressed.
Image quality/size	Image quality can be set by pressing FUNC. button. Image size can be set by pressing FUNC. button while rotating command dial.
Sensitivity	Sensitivity can be set by pressing FUNC. button and rotating command dial when camera is in mode P , S , A , or M .
Continuous	Continuous shooting mode can be set by pressing FUNC. button and rotating command dial when camera is in mode P , S , A , or M .



AE-L, AF-L

By default, both focus and exposure are locked when the AE/AF-L button is pressed. If desired, the button can be set to lock only one of focus and exposure.

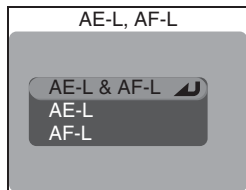

Option	Description
AE-L & AF-L	Pressing AE/AF-L button locks both focus and exposure.
AE-L	Pressing AE/AF-L button locks exposure only. Focus locks when shutter-release button is pressed halfway.
AF-L	Pressing AE/AF-L button locks focus only. Exposure locks when shutter-release button is pressed halfway.

Shot Confirmation

If **On** is selected for this option, the self-timer lamp will light after shooting to confirm that the shutter has been released. When **Multi-shot 16** is selected for **Continuous**, the lamp will light after all pictures in the series have been taken. The lamp will not light at a setting of **Ultra HS** or if the flash fired when the picture was taken.



info.txt

When pictures are recorded with **On** selected for **info.txt**, information about each image is added to an independent text file ("info.txt") stored in the same folder as the picture. When the contents of the memory card are viewed on a computer, this file can be read with a text browser such as Notepad or SimpleText. If **Off** (the default option) is selected, photo information will no longer be recorded to the info.txt file. Information about pictures recorded when **Off** is selected can still be viewed in the photo information display (📷 76).

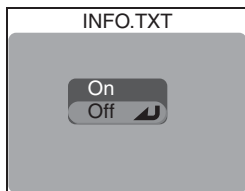

When **On** is selected, the following information is recorded:

- File number and type
- Camera type and firmware version
- Metering method
- Exposure mode
- Shutter speed
- Aperture
- Exposure compensation
- Focal length and digital zoom factor
- Image adjustment
- Sensitivity (ISO equivalency)
- White balance
- Image sharpening
- Date of recording
- Image size and quality
- Saturation control
- Active focus area

Images are listed in the order recorded, separated by a blank line.

Nikon View

The info.txt file can not be transferred to a computer using Nikon View.

The Setup Menu

USB

USB configures the camera for connection to a computer. See “More on Playback: Viewing Pictures on a Computer” (83).

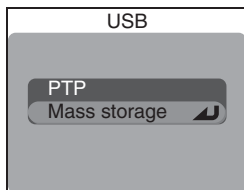

Video Mode

Before connecting your camera to a video device such as a television or VCR (82), choose a video mode setting that matches the video standard used in the device. The camera supports NTSC and PAL standards.

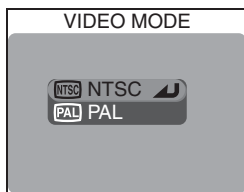

Reset All

Choose this option to restore settings to their default values.

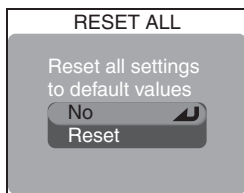

Option	Description
No	Exit menu, leaving settings unchanged.
Reset	Restore all settings except Language, Date, Video mode, and USB to default values.

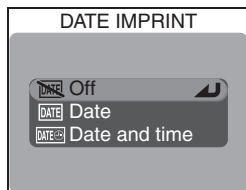

Date Imprint

This option imprints the date or the date and time of recording on still pictures as they are recorded to the memory card. It can not be used to imprint date or time stamps after recording. Imprinted data form a permanent part of the image and will appear whenever the image is printed, regardless of whether the date option is chosen in the **Print set** menu. **Date imprint** has no effect in  mode.





Option	Description
 Off	Time and date do not appear on pictures.
 Date	Date is imprinted on all stills taken while this option is in effect.
 Date and time	Date and time are imprinted on all stills taken while this option is in effect.

Firmware Version

Select this option to display the current camera firmware version. Press the multi selector to the left to return to the setup menu.



Image Quality/Size (Date Imprint)

Data imprinted at an **Image quality/size** setting of  **640 × 480** may be difficult to read. Choose a setting of  **1024 × 768** or larger when using date imprint.

Date Imprint

The date is recorded in the order selected in the date menu ( 20). Before shooting, check that the camera clock has been set to the correct date and time. You will not be able to select **Date** or **Date and time** if the camera clock has not been set.

When **Date** or **Date and time** is selected, a date imprint icon is displayed in the monitor when the camera is in , **SCENE**, **P**, **S**, **A**, or **M** mode.



Technical Notes

This chapter provides a list of the optional accessories available for your camera, tips on cleaning and storage, troubleshooting advice, and camera specifications.

Optional Accessories 📖 148

Caring for Your Camera 📖 149

Error Messages 📖 151

Troubleshooting 📖 153

Specifications 📖 156

Optional Accessories

At the time of writing, the following optional accessories were available for this camera. Contact your retailer or Nikon representative for details.

Rechargeable batteries	Additional EN-EL1 Li-ion batteries are available from your retailer or local Nikon representative
AC adapters/battery chargers	<ul style="list-style-type: none">•EH-21 AC adapter/battery charger•EH-53 AC adapter•MH-53C battery charger (plugs into vehicle cigarette-lighter socket)
Carrying case	CS-CP16 soft case
CompactFlash™ memory card adapter	EC-AD1 PC-card adapter
Converter lenses and lens adapters (require lens adapter ring)	<ul style="list-style-type: none">•FC-E9 fisheye converter (0.2×)•WC-E80 wide-angle converter (0.8×)•TC-E15ED telephoto converter (1.5×)•ES-E28 slide copy adapter
Lens adapter rings	<ul style="list-style-type: none">•UR-E9 step-down ring lens adapter for WC-80 and TC-E15ED•UR-E10 step-down ring lens adapter for FC-E9•UR-E11 step-down ring lens adapter for ES-E28
Wired remote cable	MC-EU1 remote cord
Lens hood	HN-CP10 lens hood
Filters (attach to HN-CP10 lens hood)	77-mm (3") Nikon filters
Optional Speedlights	SB-80DX, 50DX, 28DX, 30, 28, 27, 26, 25, 24, 23, and 22s

✓ Use Only Nikon-Approved Flash Accessories

Use only Nikon Speedlights. Negative voltages or voltages over 250V applied to the accessory shoe could not only prevent normal operation, but could damage the sync circuitry of the camera or flash. Before using a Nikon Speedlight not in the list above, contact a Nikon-authorized service representative for more information.

✎ Using Lens Adapter Rings

Remove optional lens adapter rings when not in use. The corners of the frame will be eclipsed in any pictures taken while a lens adapter ring is mounted on the camera without a converter lens attached.

✎ SB-27 and SB-23 Speedlights

Set **Speedlight cntrl** to **Auto** or **Internal off** when using an SB-27 or SB-23 Speedlight.

Caring for Your Camera

Cleaning

Lens/Viewfinder

One key to preserving the conditions of these glass parts is to not touch them with your fingers. Remove dust or lint with a *blower* (typically a small device with a rubber bulb attached to one end that is pumped to produce a stream of air out the other). To remove fingerprints or other stains that can not be removed with a blower, wipe the lens or viewfinder with a soft cloth, using a spiral motion that starts in the center of the lens and works out to the edges.

Monitor

Remove dust or lint with a blower. To remove fingerprints and other stains, clean the monitor with a soft, dry cloth, being careful not to apply pressure.

Avoid contact with liquid crystal

Should the monitor break, care should be taken to avoid injury due to broken glass and to prevent the liquid crystal from the monitor touching the skin or entering the eyes or mouth.

Body

Use a blower to remove dust and lint, then wipe gently with a soft, dry cloth. After using the camera at the beach or seaside, wipe off any sand or salt with a cloth lightly dampened with fresh water, then dry thoroughly.

Do not use alcohol, thinner, or other volatile chemicals.

Notes on the Monitor

- The monitor may contain a few pixels that are always lit or that do not light. This is a characteristic common to all TFT LCD monitors, and does not indicate a malfunction. Images recorded using the product will not be affected.
- When you frame bright subjects, vertical comet-like streaks that whiten toward either end may appear in the monitor. This phenomenon, known as “smear,” does not appear in the final photograph and does not indicate a malfunction. Some smear may appear in movies.
- Images in the monitor may be difficult to see in a bright light.
- The monitor is lit by an LED backlit. Should the monitor begin to dim or flicker, contact your Nikon service representative.



Storage

Turn the camera off when not in use and check that the power-on lamp is off before putting the camera away. To prevent mold or mildew, store the camera in a dry, well-ventilated area. If you will not be using the product for long periods, remove the battery to prevent leakage and store the camera in a plastic bag containing a desiccant. Do not store the camera case (available separately) in a plastic bag, as this may cause the material to deteriorate. Note that desiccant gradually loses its capacity to absorb moisture and should be replaced at regular intervals. Do not store the camera with naphtha or camphor moth balls or in locations that:

- are poorly ventilated or damp
- are next to equipment that produces strong electromagnetic fields, such as televisions or radios
- are exposed to temperatures below -10°C (14°F) or above 50°C (122°F ; for example near a space heater or in a closed vehicle on a sunny day)
- are subject to humidities of over 60%

To prevent mold or mildew, take the camera out of storage at least once a month. Turn the camera on and release the shutter a few times before putting the camera away again.









Store the battery in a cool, dry place.

Batteries

- When turning the camera on, check that the battery is charged. The monitor will display a warning when batteries are low.
- Carry a fresh 2CR5 (DL245) battery as a replacement when taking pictures on important occasions. You may find it difficult to purchase replacement batteries on short notice.
- On cold days, the capacity of batteries tends to decrease. Be sure that the battery is fully charged before heading outside to take pictures in cold weather. Keep spare batteries in a warm place and exchange as necessary. Once warmed, a cold battery may recover some of its charge.
- If the battery terminals are dirty, wipe them off with a clean, dry cloth before use.
- Used batteries are a valuable resource. Please recycle used batteries in accordance with local regulations.



Error Messages

The following table lists the error messages and other warnings that appear in the monitor and how to deal with them.

Display	Problem	Solution	
 (Flashes)	Clock not set.	Set clock to current date and time.	21
WARNING !! BATTERY EXHAUSTED	Battery is exhausted.	Turn camera off and replace battery.	18
WARNING !! THE MODE DIAL IS NOT IN THE PROPER POSITION	Mode dial is positioned between two modes.	Adjust mode dial to select desired mode.	8
WARNING !! NO MENU IN AUTO MODE PLEASE USE ANOTHER MODE	 button pressed in  (auto) mode.	To use menus, select another mode.	10
 NO CARD PRESENT	Camera can not detect memory card.	Turn camera off and confirm that memory card is correctly inserted.	16–17
 THIS CARD CANNOT BE USED	Error accessing memory card.	<ul style="list-style-type: none"> • Use approved card. • Check that connectors are clean. If card is damaged, contact retailer or Nikon representative. 	17
WARNING !! THIS CF CARD CANNOT BE READ			—
 CARD IS NOT FORMATTED FORMAT NO 	Memory card has not been formatted for use in camera.	Press multi selector down to highlight FORMAT and press to right to format card, or turn camera off and replace card.	14
 OUT OF MEMORY	<i>Camera in shooting mode:</i> Insufficient memory to record pictures at current settings.	<ul style="list-style-type: none"> • Reduce image quality or size. • Delete pictures. • Insert new memory card. 	54–57 116–117 16–17
	<i>Camera connected to computer:</i> Insufficient memory to record information needed for transfer.	Disconnect camera, delete unwanted pictures from memory card, and try again.	85, 116–117

Error Messages





Display	Problem	Solution	
 IMAGE CANNOT BE SAVED	<ul style="list-style-type: none"> •Memory card has not been formatted for use in camera, or error occurred while saving picture. •Camera has run out of file numbers. 	<ul style="list-style-type: none"> •Reformat memory card. •Insert new memory card or delete pictures. 	114 16–17, 116–117
CARD CONTAINS NO IMAGES	No pictures on memory card, or current folder contains no images.	To view pictures, select folder containing pictures from Folders menu.	122
ALL IMAGES ARE HIDDEN	All pictures in current folder are hidden.	Select another folder or use Hide image to change hidden status of pictures in current folder.	126
FILE CONTAINS NO IMAGE DATA	File created by computer or different make of camera.	View file on computer or correct make of camera.	83
THE FOLDER CANNOT BE DELETED	Folder contains hidden or protected pictures, or pictures not created with COOLPIX5400.	Folder can only be deleted if all pictures in folder are neither hidden nor protected.	125, 126
THIS IMAGE CANNOT BE DELETED	Attempt to delete protected picture.	Remove protection before deleting picture.	125
LENS ERROR	Lens operation error.	Turn camera off, then on again. If error persists, contact retailer or Nikon representative.	14
SYSTEM ERROR	Error has occurred in camera's internal circuitry.	Turn camera off, unplug optional AC adapter (if using), remove and reinsert battery, and turn camera on. If error persists, contact retailer or Nikon representative.	14

Troubleshooting



If your camera fails to function as expected, check the list of common problems below before consulting your retailer or Nikon representative. Refer to the page numbers listed in the right-most column for information on solving the problems listed here.

Electronically-Controlled Cameras

In extremely rare instances, unusual characters may appear in the monitor and the camera may stop functioning. In most cases, this phenomenon is caused by a strong external static charge. Turn the camera off, remove and replace the batteries, and turn the camera on again, or, if you are using an AC adapter (available separately), disconnect and reconnect the adapter, and turn the camera on again. In the event of continued malfunction, contact your retailer or Nikon representative. Note that disconnecting the power source as described above may result in the loss of any data not recorded to the memory card at the time the problem occurred. Data already recorded to the memory card will not be affected.

Problem	Possible cause	
Monitor is blank	• Camera is off.	24
	• Battery is not correctly inserted or battery-chamber cover is not properly latched.	14–15
	• Battery is exhausted.	18
	• AC adapter (available separately) is not properly connected.	15
	• Camera is in standby mode. Press shutter-release button halfway.	19
	• Monitor is off. Press  button.	9
Camera turns off without warning	• USB cable is connected.	83–84
	• Video cable is connected.	82
No indicators appear in monitor	• Battery is low.	18
	• Battery is cold.	150
Monitor is hard to read	• Indicators are hidden. Press  button until indicators are displayed.	9
	• Slide show in progress	123–124
Monitor is hard to read	• Ambient lighting is too bright: move to darker location or use viewfinder.	27
	• Display options require adjustment.	136–137
	• Monitor is dirty: clean monitor.	149



Problem	Possible cause	
No picture is taken when shutter-release button is pressed	<ul style="list-style-type: none"> • Mode dial is set to . • Battery is exhausted. • Message "OUT OF MEMORY" appears in monitor: insufficient memory to record picture at current image quality and size. • Green (AF) lamp flickers: camera unable to focus. • Red  lamp flickers: flash is charging. • Message "CARD IS NOT FORMATTED" appears in monitor: memory card is not formatted for use in your camera. • Message "NO CARD PRESENT" appears in monitor: no memory card in camera. 	<p>75 18 25 28 28 114 16</p>
Pictures are too dark (underexposed)	<ul style="list-style-type: none"> • Flash is off. • Flash window is blocked. • Subject is outside range of flash. • Exposure compensation is too low. • Shutter speed blinks: shutter speed too fast. • Aperture blinks: f/-number too high. 	<p>32 33 33 36 50, 52 51–52</p>
Pictures are too bright (overexposed)	<ul style="list-style-type: none"> • Exposure compensation is too high. • Shutter speed blinks: shutter speed too slow. • Aperture blinks: f/-number too low. 	<p>36 50, 52 51–52</p>
Pictures are out of focus	<ul style="list-style-type: none"> • Subject was not in focus area when shutter-release button was pressed halfway or AE/AF-L button was pressed. • Green (AF) lamp flickers: camera unable to focus. • Manual focus distance does not match distance to subject. 	<p>28 28 72</p>
Pictures are blurred	<ul style="list-style-type: none"> • Camera shook during shot: choose faster shutter speed. If shutter speed can not be increased without causing underexposure: <ul style="list-style-type: none"> ◆ Use the flash ◆ Zoom camera out ◆ Raise sensitivity (ISO equivalency) ◆ Select larger aperture (smaller f/-number) To minimize blur at slow shutter speeds: <ul style="list-style-type: none"> ◆ Use Best Shot Selector (BSS) ◆ Mount camera on tripod and use self-timer 	<p>50, 52 32–33 26 58–59 51–52 97 35</p>



Problem	Possible cause	
Randomly-spaced bright pixels appear in image (“noise”)	<ul style="list-style-type: none"> • Sensitivity (ISO equivalency) too high. • Shutter speed too slow. At shutter speeds of $\frac{1}{4}$ s or slower, turn noise reduction on. 	58–59 50, 52, 111
Flash does not fire	<ul style="list-style-type: none"> • Flash is off. Flash turns off automatically when: <ul style="list-style-type: none"> ◆ Focus mode is set to ▲ (infinity) ◆ Landscape, Sunset, Night landscape, Museum, Fireworks show, Close up, Copy, Panorama assist, Sports, or Dusk/Dawn selected in SCENE mode ◆ Continuous is set to option other than Single ◆ BSS is on ◆ Lens is set to option other than Normal ◆ AE lock is on ◆ Speedlight cntrl is set to Internal off ◆ Optional Speedlight is attached and Speedlight cntrl set to Auto • Battery is low. 	32–33 34 37–45 63 97 101 103 106 106, 148 18
Colors are unnatural	<ul style="list-style-type: none"> • White balance does not match light source. • Saturation control is too low or too high. 	60–62 67
Can not create small picture	Small pictures can not be created in quick review or from movies, small pictures, or pictures taken at Ultra HS or image quality of HI.	81
Can not zoom in on picture	Can not zoom in on movies, small pictures, or pictures taken at Ultra HS .	79
TV blank when video cable connected	Video cable not correctly connected, TV not tuned to video channel, or Video mode not set correctly.	82, 144
Nikon View does not start when camera is connected or memory card inserted in card reader or card slot.	<ul style="list-style-type: none"> • Camera is off, AC adapter (available separately) is not properly connected, or battery is exhausted. • USB cable is not correctly connected, or card not properly inserted in card reader or card slot. • USB item in setup menu set to PTP when camera connected to computer running Windows 2000 Professional, Windows Millennium Edition (Me), Windows 98 Second Edition (SE), or Mac OS 9. • Nikon View is not installed. See <i>Nikon View Reference Manual</i> (on CD) for more information.	15, 18, 24 84 83 —

Specifications

Type	E5400 digital camera
Effective pixels	5.1 million
CCD	1/1.8" high-density CCD; total pixels: 526 million
Image size (pixels)	<ul style="list-style-type: none"> • 2,592 × 1,944 • 1,280 × 960 • 640 × 480 • 1,600 × 1,200 • 1,024 × 768 • 2,592 × 1,728 (3:2)
Lens	4 × Zoom Nikkor, F=5.8–24 mm (35-mm [135] camera-format equivalent: 28–116 mm), f/2.8–f/4.6 (nine elements in eight groups)
Digital zoom	4 × (35-mm [135] camera-format equivalent: 460 mm)
Autofocus (AF)	Contrast-detect through-the-lens (TTL) AF
Focus range	50 cm (1'8")–∞; macro mode 1 cm/0.4" (W)–∞
Focus-area selection	Five-area multi AF and spot AF available
Viewfinder	Real-image zoom viewfinder with LED indication
Magnification	0.26–0.92 ×
Frame coverage	Approximately 80% horizontal and 80% vertical
Diopter adjustment	–3 – +1 m ⁻¹
Monitor	1.5", 134,000-dot High Transmissive Advanced TFT LCD monitor with brightness and hue adjustment
Frame coverage (shooting)	Approximately 97% horizontal and 97% vertical
Storage	
Media	Type I and II CompactFlash™ (CF) and Microdrive cards
File system	Compliant with Design Rule for Camera File System (DCF), Exif 2.2, and Digital Print Order Format (DPOF)
File formats	Uncompressed: TIFF-RGB (HI-quality images) Compressed: JPEG-baseline-compliant (1:4, 1:8, 1:16) Movies: Quick Time
Exposure	
Metering	Four-mode through-the-lens (TTL) metering <ul style="list-style-type: none"> • 256-segment matrix • Spot • Center-weighted • AF spot
Exposure control	Programmed auto exposure with flexible program, shutter-priority auto, manual, exposure compensation (–2.0–+2.0EV in steps of 1/3EV), autoexposure bracketing
Range	W: –1.0–+18.0EV T: +0.5–+18.0EV

Shutter	Mechanical and charge-coupled electronic shutter
Speed	1– $\frac{1}{4,000}$ s (auto, scene, and programmed auto), 8– $\frac{1}{4,000}$ s (shutter-priority auto and aperture priority auto), BULB (up to 10 min) and 8– $\frac{1}{4,000}$ s (manual exposure mode), $\frac{1}{30}$ – $\frac{1}{8,000}$ s (Ultra HS)
Aperture	Six-blade iris diaphragm
Range	Ten settings in steps of $\frac{1}{3}$ EV (to minimum of f/8)
Sensitivity	Approximately equivalent to ISO 50, 100, 200, 400; Auto (auto gain to ISO 200 equivalent)
Self-timer	Approximately ten- or three-second duration
Built-in Speedlight	
Range (Auto ISO)	0.5–4.5 m/1'8"–14'9" (W); 0.5–2.8 m/1'8"–9'2" (T)
Sync method	Automatic sync control
Accessory shoe	Standard ISO hot-shoe contact with safety lock
Sync contact	X-contact only
Interface	USB
Video output	User can choose from NTSC and PAL
I/O terminals	<ul style="list-style-type: none"> • DC in • Audio/video out • Data output (USB)
Power sources	<ul style="list-style-type: none"> • One rechargeable Nikon EN-EL1 lithium-ion battery (supplied) or six-volt 2CR5 (DL245) lithium battery (available separately) • EH-53 AC adapter • EH-21 AC adapter/battery charger
Approximate battery life	110 min (EN-EL1). Measured at standard temperature (20°C/68°F) with fully-charged batteries under standard Nikon test conditions: zoom adjusted with each shot, flash used in approximately one third of shots, image quality set to NORMAL.
Dimensions (W × H × D)	108 × 73 × 69 mm (4.3" × 2.9" × 2.7")
Approximate weight	320 g (11.3 oz) without battery or memory card
Operating environment	
Temperature	0–40°C (32–104°F)
Humidity	Less than 85% (no condensation)

Index

Symbols

- 1, 2, 99
 - 50, 100, 200, 400, 58–59
 - see Auto mode, Mode dial
 - see Image quality, Image size, Mode dial
 - see Mode dial, Movie mode
 - see Mode dial, Playback mode
 - button, 5, 31, 75, 78, 80
 - button, 4, 36
 - button, 4, 33
 - button, 5, 9
 - button, 5, 81
 - button, 5, 78
 - button, 4, 80
 - button, 5, 79
 - 18, 33, 76
 - 67
 - BSS, AE, 96–97
 - 21, 151
 - 63
 - 145
 - 7, 36
 - 32, 108
 - 34, 72
 - 66
 - 101–102
 - 68
 - 76
 - 29
 - 60
 - lamp, see Lamp, red ()
- A**
- A, see Exposure mode, A (aperture priority auto)
 - Accessories, see Optional accessories
 - Accessory shoe, 4, 106–107
 - AC adapter, ii, iv, 3, 15, 91, 140, 148, 157
 - AE-L**, 30, 44, 103
 - AE-L, AF-L**, 30, 141, 142
 - AE/AF-L button, 5, 30
 - AE lock**, 103, 155
 - AF, see Autofocus

- AF area mode**, 68, 69–70
- button, 5, 34, 35
- AF lamp, see Lamp, green (AF)
- Aperture, 25, 49, 51, 52, 154
- Audio, see Movies, Voice memo
- Audio/Visual, see Playing pictures back, on TV
- Auto**, see Flash mode, Sensitivity
- Auto-focus mode**, 70
- Autofocus, 24, 28–30, 34–35, 38
- Auto bracketing**, 95, 109–110
- Auto mode, 8, 24–31
- Auto off**, 19, 123, 134, 140
- Auto transfer**, 115, 129–130
- AV OUT, see Playing pictures back, on TV

- B**
- Back light**, 37, 42
 - BASIC, 54
 - Batteries, ii–iii, 3, 14–15, 18, 150, 157
 - 2CR5 (DL245), ii, iii, 15, 140, 150, 157
 - EN-EL1, ii, 14–15, 148, 157
 - charging 14

- Beach/Snow**, 37, 39
- Best Shot Selector, see BSS
- Black-and-white, 67
- Blur, 38, 97, 154
- Brightness**, 137
- BSS**, 41, 95, 96–97, 154, 155
- BULB, see **Bulb/Time**, Long time-exposures
- Bulb/Time**, 53, 104

- C**
- Camera strap, ii, 5
 - CF card, see Memory card
 - CF card format**, 95, 114, 115, 134
 - Clock, see **Date**
 - Close up**, 37, 41, 69, 155
 - Close ups, 34, 41, 72

- Command dial, 4
- CompactFlash™, see Memory cards
- Compression, see Image quality
- Computer. See also E-mail, Nikon View, Printing pictures, Transfer
- copying pictures to, 83–85
- Continuous**, 63–64, 95, 155
- Contrast, see **Image adjustment**
- Controls**, 30, 134, 141–142
- Copy**, 37, 42, 155
- Copying pictures, see **Move image**, Transfer

- D**
- Date**, 20–21, 134
 - Date, 20–21, 76
 - printing on pictures, 86, 145
 - Date imprint**, 86, 134, 145
 - DCF, 3, 156
 - Delete**, 115, 116–117
 - Deleting pictures, 75, 116–117
 - all pictures, 117
 - all pictures in folder, 121
 - during shooting, 75
 - in full-screen playback
 - 31, 75
 - selected pictures, 116–117
 - Design Rule for Camera File System, see DCF
 - Digital Print Order Format, see DPOF
 - Digital tele**, 105
 - Diopter adjustment, 27
 - Display mode**, 137
 - DPOF, 86, 127, 128
 - Dusk/Dawn**, 37, 43, 155

- E**
- E-mail, 54–55, 81
 - Exif 2.2, 3, 156
 - Exif Print, see Exif 2.2
 - Exposure bracketing, 109–110
 - Exposure BSS**, 97

- Exposure compensation, 36, 154
- Exposure information, see Photo information
- Exposure lock, 30, 142
- Exposure metering, see Metering
- Exposure mode, 8, 24, 48–53
 - A (aperture-priority auto) 51
 - M (manual) 52–53
 - P (programmed auto) 49
 - S (shutter-priority auto) 50
- Exposure options**, 95, 103–104
- F**
- Files, see Image files
- File numbering, 138
- Fill flash, 32, 42
- FINE, 54
- Fireworks show**, 37, 41, 155
- Firmware version**, 134, 145
- Fixed aperture**, 51, 105
- Flash, iii, 32–33, 106–108, 154, 155, 157
 - built-in, 4, 28, 64, 106
 - mode, 25, 32–33, 38–44
 - optional, 32, 64, 106, 108, 148
 - range, 33, 157
 - repeating, 32, 107
- Flash exp. comp.**, 106
- Flash exposure compensation, 106
- Flash-ready lamp, , see Lamp, red (🔴)
- Flexible program, 49
- Focus, 28–30, 34–35, 72, 156
- Focus area, 27, 28, 69–70
- Focus confirmation**, 71, 72
- Focus information, see **Focus confirmation**, Photo information
- Focus lock, 9, 30, 69, 142
- Focus mode, 34–35, 38–44, 72, 154
- Focus options**, 69–71, 95
- Folders, 115, 118–122, 134, 135
 - choosing for playback, 122
 - creating, 119
 - deleting, 121
 - renaming, 120
 - storing pictures in, 135
- Formatting, see Memory card, formatting
- Framing pictures, 26
- FUNC**, 141
- FUNC. button, 4, 141
- H**
- Hi, 54, 75
- Hidden pictures, 117, 121, 126
- Hide image**, 115, 123, 126
- Hue**, 137
- I**
- Image adjustment**, 66, 95
- Image files, 89, 138
- Image quality, 8, 25, 54
- Image quality/size**, 54–57, 95
- Image sharpening**, 65, 95
- Image size, 8, 25, 55
- Infinity, see Focus mode, Manual focus
- info.txt**, 132, 134, 143
- Information, see Photo information
- ISO, see Mode dial, Sensitivity
- J**
- JPEG, 54, 156
- JPG, 138
- L**
- Lamp, green (AF), 5, 9, 28, 154
- Lamp, red (🔴) 5, 28, 33, 154
- Landscape**, 37, 40
- Language**, 20, 134
- Language, choosing, 20
- Lens, iv, 4, 149, 155, 156
- Lens**, 95, 101–102
- Lens, converter, 27, 101, 148
- Lens adapter ring, 101, 102, 148
- Lens cap, 5
- Long time-exposures, 53, 104
- M**
- M**, see Exposure mode, M (manual)
- Macro close-up, 34
- Manual focus, 35, 72
- Memory cards, iii, 16–17, 156
 - approved, 17
 - formatting, 17, 114, 125, 126
 - insertion and removal of, 16–17
- Menus, 10–11, 93–145
 - MENU** button, 5
- Metering**, 30, 68, 95
- MF button, 5, 72
- Microdrive, see Memory cards
- Microphone, built in, 4, 80, 88
- Mode dial, 4, 8
- Monitor, iii, iv, 5, 6–7, 9, 26–31, 149, 153, 156
 - brightness and hue, 137
 - framing pictures in, 27–28
 - indicators in, 7, 153
 - opening and closing, 6
 - turning on and off, 9
- Monitor options**, 134, 136–137
- Monochrome, see Black-and-white
- MOV, 138
- Move image**, 115, 131–132
- Movies, 87–92, 156
 - recording, 88–91
 - viewing, 92
- MOVIE menu, 89
- Movie mode, 8, 75, 82, 88–91
- Moving pictures, 131–132
- Multi selector, 5
- Museum**, 37, 41, 155
- My menu**, 94, 95, 113–114
- N**
- Night landscape**, 37, 40, 155
- Night portrait**, 37, 39
- Nikon View, 83–85, 129, 155

Noise, 33, 40, 111

Noise reduction, 33, 40, 58, 64, 111

Noise reduction, 95, 111

NORMAL, 54

NR, 40, 111

NTSC, see Video mode

Number of exposures remaining, 25

O

On/off, see Power switch

Optional accessories, 107, 148

P

P, see Exposure mode, P (programmed auto)

PAL, see Video mode

Panorama, 44–45, 103

Panorama assist, 37, 42, 44–45, 122, 135, 155

Party/Indoor, 37, 39

Photo information, 76–77

PLAYBACK MENU, 93, 115–133

Playback mode, 8, 73–81

Playing pictures back, 31

full-screen, 31, 74–81

in quick review, 74

movie playback, 92

on a computer, 83–85

on a TV, 82

Portrait, 37, 39, 69

Portraits, 39, 68

Power-on lamp, 4, 24

Power switch, 4, 24

Printing pictures, 55, 86,

127–128. See also **Date**

imprint, DPOF

Print set, 86, 115, 127–128

Protect, 115, 125

Protected pictures, 117, 121, 125

Q

Quality, see Image quality

 button, 5, 74

Quick review, 74

Quick Time, see Movies

QVGA, see **Continuous**

R

Red-eye reduction, 32

Release speed, 136

Repeating flash, 32, 107

Reset, 95, 112

Reset all, 134, 144

Resizing pictures, 81, 155

S

S, see Exposure mode, S (shutter-priority auto)

Saturation control, 67, 95, 155

SCENE mode 8, 37–45

Self-timer, 35, 157

Self-timer lamp, 4

Sensitivity, 32, 58–59, 95, 154, 155, 157

Seq. numbers, 134, 138

SET-UP menu, 93, 134–146

Setup mode, 8, 20–21, 134–146

Shooting menu, 93, 94–114

Shot confirmation, 134, 143

Show all menus, 94

Shutter-release button, 4, 9, 28–29

Shutter-release delay, see Self-timer

Shutter sound, 134, 139

Shutter speed, 25, 49, 50, 52, 154

Slide show, 115, 123–124

Slide shows 123–124

Small pic, 81, 115, 133

Smear, 149

Speaker, built-in, 4, 80, 92

Speedlight, see Flash

Speedlight cntrl, 106, 155

Speedlight opt., 95, 106–108

Sports, 37, 43

Standby mode, 19, 123, 140

Sunset, 37, 40, 155

T

Telephoto, see Zoom

Television, 144

connecting to 82

Thumbnail playback, 78

TIF, 138

TIFF, 54

Time-lapse movie, 89, 90–91, 92

Time-lapse photography, 90–91

Transfer, 83–85

marking pictures for, 129–130

 button, see Zoom, buttons

U

Ultra HS, 63, 64, 75, 82, 122, 135

USB, 83, 134

USB, 83–84, 155

cable (UC-E1) 84

User setting, 95, 98–99

V

VCR, 82, 144

Video cable (EG-E5000), 82

Video mode, 82, 134, 144

Viewfinder, ii, iii, 4, 5, 26–27,

149, 156

focus, 27

framing pictures in, 27

Voice memos, 80

W

WB, 8, 60–61, 108

White balance, 60–62, 95, 155

bracketing, 109

fine tuning, 61

preset, 62

Wide angle, see Zoom

 button, see Zoom, buttons

Z

Zoom, 26, 51, 156

buttons, 5, 26, 78–81

digital, 26–27, 54, 64, 69, 156

indicator, 26

optical, 26

playback, 79, 155

Zoom options, 51, 95, 105

Nikon

NIKON CORPORATION

Fuji Bldg., 2-3 Marunouchi 3-chome,
Chiyoda-ku, Tokyo 100-8331, Japan

Printed in Japan
SB3C07000201(11)
6MAA6211--